

---

## SHOCK AND VIBRATION INDICATORS AND RECORDERS

---

### **1.0 SCOPE**

This standard provides instruction for installing shock and vibration indicators in packaged products.

### **2.0 REFERENCES**

The following information is intended as a guide or aid to suppliers in meeting the requirements of this specification.

#### **Commodity**

Shock Watch Indicators

Shock Timer

Multi-G-Clip

MAG 2000®

SHOCK MASTER®

EDR-3C

SAVER 3D15

#### **Military/Commercial Specification**

Commercially Available (Suggestion: ShockWatch, Inc.)

Commercially Available (Suggestion: Instrumented Sensor Technology, Inc.)

Commercially Available (Suggestion: ShockWatch, Inc.)

Commercially Available (Suggestion: ShockWatch, Inc.)

Commercially Available (Suggestion: AGM Container Controls, Inc.)

Commercially Available (Suggestion: Instrumented Sensor Technology, Inc.)

Commercially Available (Suggestion: Lansmont Instruments)

### **3.0 REQUIREMENTS**

#### **3.1 GENERAL**

**CAUTION:** Shock and vibration indicators and recorders shall only be utilized when handling shock or transportation vibration requirements are established in product specifications or engineering drawings. The trigger level must be at or below the levels established in the product specification or drawing. Request assistance from Product Protection Engineering when any of these applications are required.

NOTE: Certified Principal Engineers (CPEs) may impose the use of shock and vibration indicators and recorders on development units without establishing requirements in specification or drawings.

## P-134

Revision 1

Page 2

08-27-2008

Shock and vibration indicators and recorders need to be correctly positioned to operate properly. Incorrect placement can alter the device's response characteristics and cause erratic results. If indicators are reused, ensure that their fastening mechanism is secure and not worn. Single trip indicators shall be scrapped after they have been activated. Shock and vibration recorders must be calibrated prior to use. Shock and vibration indicators and recorders shall be installed on the product, product fixture or installed on the inner unit containers of a box-in-a-box packaging configuration (See Figure 1). Indicators and recorders shall not be applied to the exterior of a shipping container. Indicators and recorders must be applied to a firm surface—application to flexible wrapping or bagging material is not acceptable.

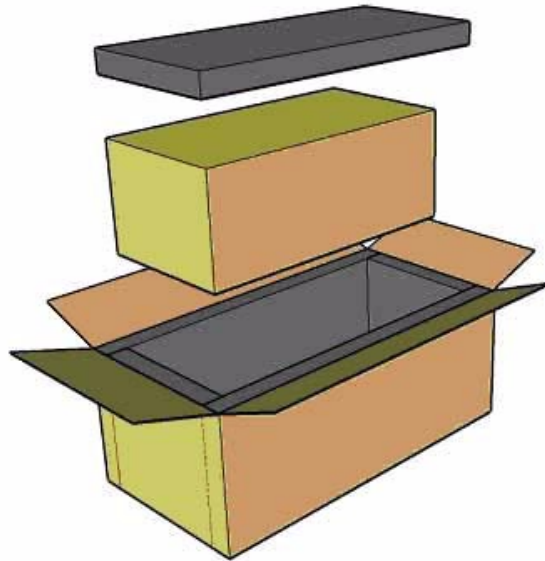

Figure 1. Box-in-a-Box Packaging Configuration

### 3.2 SHOCKWATCH® INDICATORS

ShockWatch® shock detection lables, clips, and tubes use a capillary tube with surface energy differences in each end. A color-filled liquid is placed in the -philic end, and when forces exceed a predetermined value the liquid is forced into the -phobic end, where it is visible. ShockWatch® indicators are single trip and are reusable if not activated. ShockWatch® indicators measure shock in 3 axes. ShockWatch® indicators measure acceleration in ranges from 10 to 100 G's. The most common indicators in use trigger at accelerations of 25G (Yellow Label), 50G (Red Label) and 75G (Orange Label). ShockWatch® indicators shall be applied to the product or the inner unit container as shown in Figure 2. For containers greater than 3 ft. in length or width, the indicators shall be applied on opposite 90 degree corners.



Figure 2. Tri-Axial Shock Watch Indicator

3.3 INSTRUMENTATED SENSOR TECHNOLOGY (IST) SHOCK TIMER®

The Shock Timer® is a single trip non-reusable indicator that measures 2 axis respectively. They are required on two adjacent surfaces as shown in Figure 3. Shock Timer® indicators are available with an additional battery activated Time-Stamp sensor that records the time of impact. The Shock Timer® is available in 25G and 50G models. Shock Timer® indicators shall be applied to the product or the inner unit container as shown in Figure 3. For containers greater than 3 ft. in length or width the indicators shall be applied on opposite 90 degree corners.

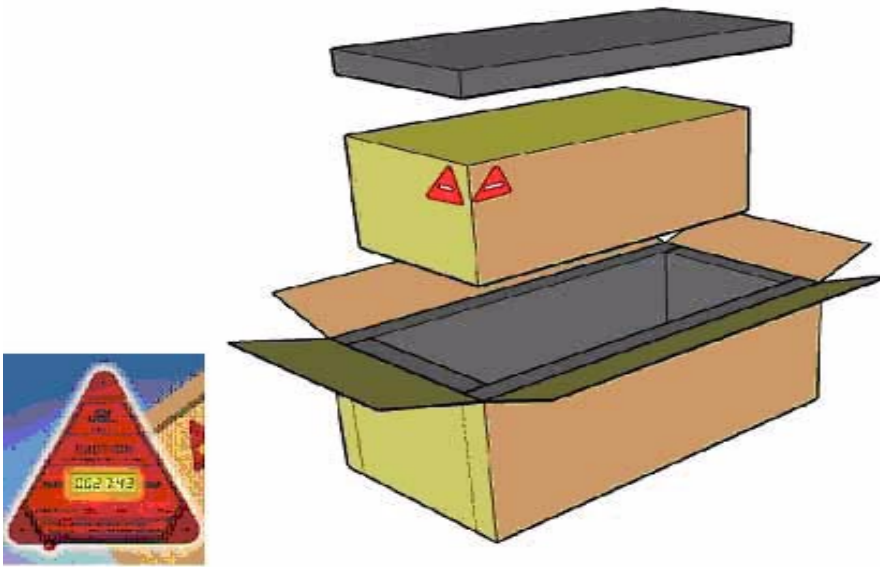

Figure 3. Bi-Axial IST Shock Timer

3.4 SHOCKWATCH® MULTI G CLIP®

The Multi G Clip® measures in 3 axes and is reusable if not activated. The Multi G Clip® indicates shock acceleration at 3 trigger ranges (typically 25, 50 and 75 G's). The Multi G Clip® shall be attached to the product or the inner unit container as shown in Figure 4. For containers greater than 3 ft. in length or width an additional indicator shall be applied on an opposite 90 degree corner.

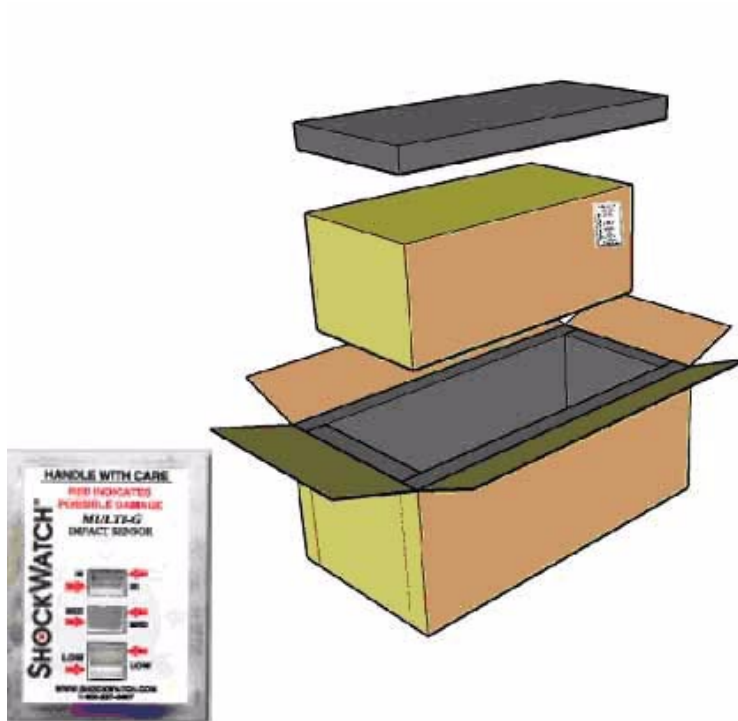

Figure 4. Tri-Axial Shock Watch Multi-G Clip

3.5 SHOCKWATCH® MAG 2000®

Magnetic shock indicators use two sensitive magnets—a lower magnet held rigidly in place and an upper magnet held in place by the mutual magnetic field attraction. When shock acceleration is encountered at a force greater than the magnetic field, the upper magnet is forced off its “home” position within the device. The Shock Watch® MAG 2000® is a single trip reusable indicator that measure in 2 axes. It can also indicate the direction of the impact. Trigger levels are available in a wide variety of settings from 1/2 to 25 G’s. The ShockWatch® MAG 2000® should be mounted as close to the product center of gravity as possible, with its sensitive axis on a plane in line with the applied force. If the indicator is not placed on the product, two indicators shall be secured to the inner unit container—one on the top and one on the side or end (see Figure 5).

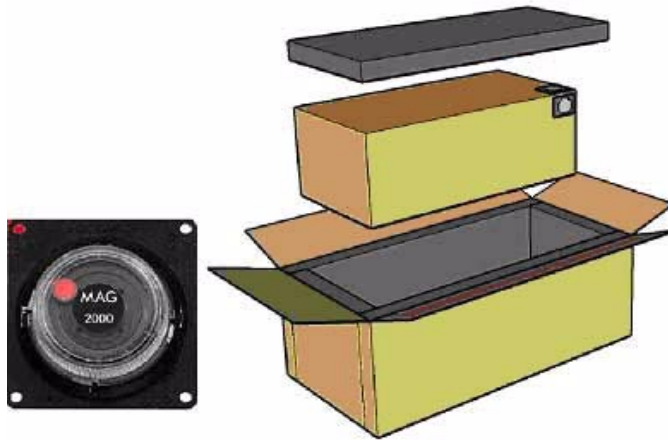

Figure 5. Bi-Axial ShockWatch MAG 2000 Indicator

### 3.6 AGM SHOCK MASTER®

The Shockmaster® is a single trip reusable indicator that measures 2 axes. The Shockmaster® consists of a spring-loaded weight with an integral trigger which engages with a spring-loaded sleeve. When tripped, this sleeve moves along a guide rod and exposes a red band on this rod. The whole assembly is enclosed in a metal housing and transparent dome.

If the shock is applied to the indicator's base, the weight will be forced down against the spring. If the shock is applied from any side direction, the weight tips against the spring. Either movement disengages the trigger from the sleeve, which then moves under the action of its spring, tripping the indicator by exposing the red band. The Shockmaster® can be reset by inserting a wire, such as a straightened paper clip, into the hole on the side of the dome and pushing the sleeve back to its cocked position. For models of 25 G and over, a plunger in the dome is depressed while the sleeve is pushed back.

Shockmaster® indicators shall be applied to the product to the product or the inner unit container as shown in Figure 6. Typical Shockmaster® models are sensitive to all acceleration forces except those coming from the top (i.e. passing through the hemisphere occupied by the plastic dome). Two equal-G Shockmasters® mounted back-to-back will cover shocks from all possible directions. For long containers, it will be advantageous to have a Shock Indicator at each end of the package.

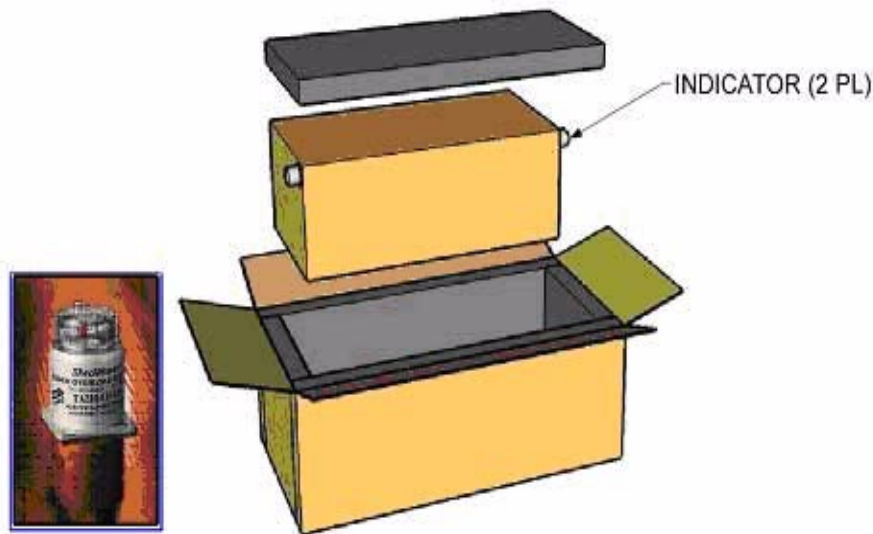

Figure 6. Bi-Axial AGM Shockmaster

**3.7 SHOCK AND VIBRATION ENVIRONMENTAL RECORDERS**

Programmable electronic recorders monitor acceleration time histories for all shock and vibration events, and may also be designed to measure temperature, humidity, and pressure within the packages. The programmable recorder tags all acceleration events (using its internal or external triaxial accelerometers) with a time and date to provide a history of the dynamic environment events that are experienced during a recording session. Environmental recorders typically fall within the capital equipment category when procured. They shall be coded as a calibrated instrument in the property management system. Examples of environmental recorders are shown in Figure 7.

Operating variables used to configure these recorders typically include trigger level, pre- and post-trigger samples, and sampling rate. The user needs to consider the amount of time that the recorder will be active and the number of events that the recorder can capture within its memory. The trigger level should be set high enough to avoid continuously triggering the recorder, yet low enough to record potentially damaging events (typically 2 g). Adjusting the recorder's threshold to a low setting may cause the memory to overload before the transportation duration is complete. Generally, pre-trigger and post-trigger times are set at 50 and 250 rms, respectively.

The recorder or its external accelerometers should be mounted as close to the product center of gravity as possible. Its sensitive axis should be on a plane that passes through the center of gravity and directly in line with the applied force. The Dynamics organization should be consulted to review mounting locations and fastening methods.



EDR-3C from Instrumented Sensor Technology (IST)



SAVER 3D15 from Lansmont Instruments

Figure 7. Examples of Shock & Vibration Environmental Recorders



3.8 MARKING

Exterior shipping containers shall be marked or labeled with text similar to the following:

“Caution: Inspect shock indicators (or environmental recorders) inside container for indication of damage”.

3.9 QUALITY ASSURANCE

A non-conformance shall be generated if a shock indicator is tripped or if recorder data exceeds the handling shock of transportation vibration limits established in product specifications or engineering drawings. Non-conformances are not required for if the indicator or recorder is attached to the exterior shipping container.

**4.0 NOTES**

N/A

