

# LMSSC PACKAGING STANDARD

P-106

Revision 2

Page 1 of 5

04-15-2009

---

## BEARING/BEARING ASSEMBLIES PACKAGING

---

### 1.0 SCOPE

This standard provides for the preservation and packaging of antifriction bearings/bearing assemblies.

### 2.0 REFERENCES

- 2.1 Lockheed Packaging Standard LPS 40-001 (General Requirements Specification)

### 3.0 REQUIREMENTS

#### 3.1 GENERAL

- 3.1.1 Unless otherwise specified, the quantity per unit package shall be one (1) each or one set (as applicable).

**NOTE:** For exception see miniature bearing packaging (Ref Paragraph 3.2.4).

- 3.1.2 When specified in the procurement document, specification/ drawing, bearings shall meet the environment/process cleanliness requirements of MIL-B-197, Level A.
- 3.1.3 Preservatives/lubricants employed shall be proper for the type of bearing, and meet the technical operation/performance specification requirements.
- 3.1.4 Intimate packaging materials shall be cleaned to the same level of cleanliness when specified for the bearing(s).
- 3.1.5 Containers constructed from plastic materials shall be of durable construction, moistureproof/dustproof, and shall be compatible with the type of preservative used for the bearing(s).
- 3.1.6 Unless otherwise specified, suppliers may select any unit package referenced in this standard (see Paragraph 3.2.3), providing that other provisions (Ref Paragraph 3.0) are met.

#### 3.2 UNIT PACKAGING – TYPE I (Figure 1)

- 3.2.1 Unless otherwise specified, each bearing (miniature type excepted) shall be preserved and wrapped in a greaseproof/waterproof material. Secure wrap with tape or equivalent method, to prevent entry of dust or other contaminants.

- 3.2.1.1 Place preserved/wrapped bearing in a folding, setup or metal-stayed style box (supplier option). Fill voids as required to immobilize bearing within the box.

- 3.2.2 Bearings weighing in excess of five (5) pounds, preserved and wrapped per Paragraph 3.2.1, shall be placed in a corrugated container. Fill voids as required.

#### 3.2.3 Unit Packaging – Type 2 (Figure 2)

- 3.2.3.1 When specified, miniature type bearings may be packaged in a clear, plastic package with provisions for individual compartment/blister. The depth of compartment/blister shall be greater than the thickness of the contained bearing. The quantity per unit package shall not exceed ten (10).

- 3.2.3.2 The plastic package shall provide breakaway, cutaway capability for dispensing each bearing individually without loss of seal or preservative.

#### 3.2.4 Unit Packaging – Type 3 (Figure 3)

- 3.2.4.1 When specified, miniature type bearings shall be individually wrapped/preserved or immersed in preservative. Place preserved bearing(s) in a clear plastic vial and securely close lid/cover.

- 3.2.4.2 The size of the vial(s) shall be commensurate with the size of the bearing(s). Lids/covers shall be designed for multiple resealing.

- 3.2.4.3 Unless otherwise specified, quantity per unit package shall not exceed ten (10).

#### 3.2.5 Unit Packaging – Type 4 (Figure 4)

- 3.2.5.1 Preserve/wrap bearing(s) in accordance with Paragraph 3.2.1.

- 3.2.5.2 Place preserved/wrapped bearing in a water vaporproof bag conformal to MIL-B-131, Class I, or MIL-PRF-22191, Type I, Class 1. Include cushioning as required to protect the bearing and close bag by heat sealing.

**NOTE:** Allow sufficient excess material to permit at least two additional heat seals.

3.3 INTERMEDIATE PACKAGING – (Consolidation of unit packages, when applicable)

- 3.3.1 Unless otherwise specified, the number of unit packages per intermediate container (containing identical parts) shall be limited to the dimensions and gross weight provisions of the container specification (Ref Carrier Regulations).
- 3.3.2 Fill all voids with suitable dunnage, blocking or bracing to prevent damage during handling/shipment.

3.4 PACKING

- 3.4.1 Pack appropriate number of intermediate containers uniformly into each shipping container.
- 3.4.2 Shipping containers as packed shall protect the item from damage during ordinary handling/shipping and shall meet the minimum requirements of common carriers for safe transportation at the lowest rate to the point of delivery.
- 3.4.3 Unit or intermediate containers which meet the requirements of Paragraph 3.4.2 may be used as shipping containers.
- 3.4.4 Enclose or attach a copy of packing slip to the shipping container.

3.5 MARKING (Unless otherwise specified in the contract or Purchasing Document use the following criteria)

- 3.5.1 Unit Package Marking – Label or mark each package, compartment, or blister (as applicable), to show at least the part number per contracting document, quantity, and supplier identity. Additional markings may be specified in the item detail specification or drawing.
- 3.5.2 Intermediate Packaging Marking – Label or mark each container to at least show part number per contracting document, supplier and quantity of parts.
- 3.5.3 Shipping Container Marking – Label or mark each container to show part number per contracting document, the LMSSC contracting document number, supplier, destination and quantity of parts.
- 3.5.4 Special, precautionary and handling markings shall be applied as required.

**4.0 QUALITY ASSURANCE**

- 4.1 Packaging shall be accomplished in such a manner as to prevent physical damage to, or degradation of, the packaged items during delivery to the using activity. It shall be the prerogative of LMSSC to return damaged items, at supplier's expense, when such damage is attributable to improper or inadequate protection.

**5.0 NOTES**

5.1 The following information is intended as a guide or aid to suppliers in meeting the requirements of this specification.

5.1.1 REFERENCES

<u>Commodity</u>	<u>Military/Commercial Specifications</u>
Barrier, Greaseproof/Waterproof	MIL-B-121
Barrier, Greaseproof/Heat Sealable	MIL-PRF-22191, Type 1, Class 1
Barrier, Water Vaporproof	MIL-B-131, Class 1
Barrier, Water Vaporproof	MIL-PRF-22191, Type 1, Class 1
Bearings, Antifriction	MIL-B-197
Box, Corrugated	ASTM D5118, Type CF, Class Domestic, SW (optional), Style RSC, Grade 44 ECT or 200 Mullen (optional)
Box, Folding	PPP-B-566
Box, Metal-Stayed	PPP-B-665
Box, Setup	PPP-B-676
Cushioning, Cellulosic	A-A-1898, Grade 1, Class C, Style 1, Size L.
Sheet, Plastic	A-A-3174, Type 1, Class 1, Grade B
Fiber Box, Closing	ASTM D1974

**Table 1**

<b>LPS Suffix</b>	<b>Method of Packaging</b>	<b>Figure Reference</b>
A	Preservation/packaging shall be in accordance with the supplier's commercial packaging, providing that the provisions of Paragraph 3.0 are met	
B	Preservation/packaging shall be in accordance with Method 41 (IA-8) of Specification MIL-STD-2073	Figure 4
C	Preservation/packaging shall be in accordance with Method 44 (IA-13) (plastic vial) of Specification MIL-STD-2073	Figure 3
D	Preservation/packaging shall be in accordance with Method IA-18 (blister), compartment package, Ref Specification MIL-B-197	Figure 2
E	Preservation requirements shall be in accordance with the LMSSC detail bearing specification/drawing	Figure 1 through Figure 4 (as applicable)
F	Preservation/packaging shall be in accordance with any applicable method of Specification MIL-B-197 suitable for the type of bearing	See MIL-B-197

**P-106**

Revision 2

Page 4

04-15-2009

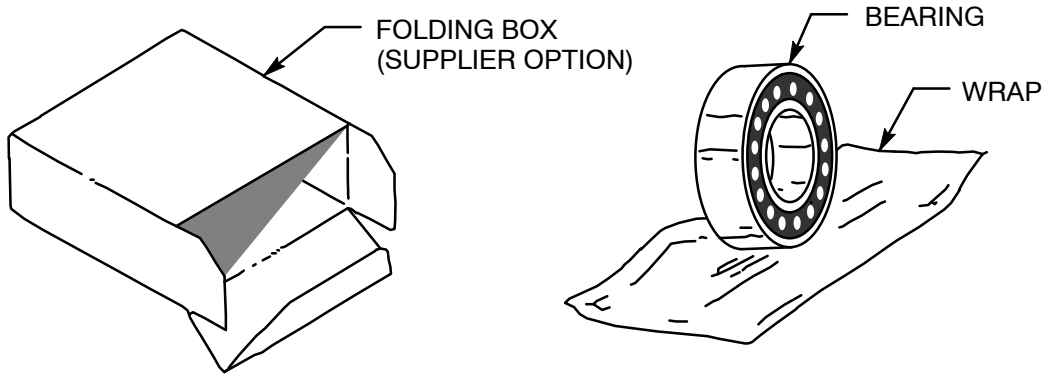

Figure 1. Unit Package – Type 1

P10131-001

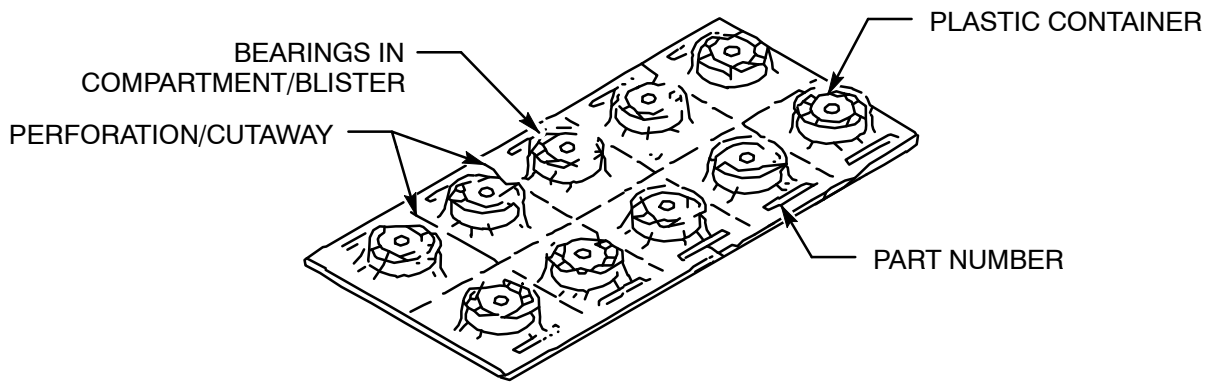

Figure 2. Unit Package – Type 2

P10026-002

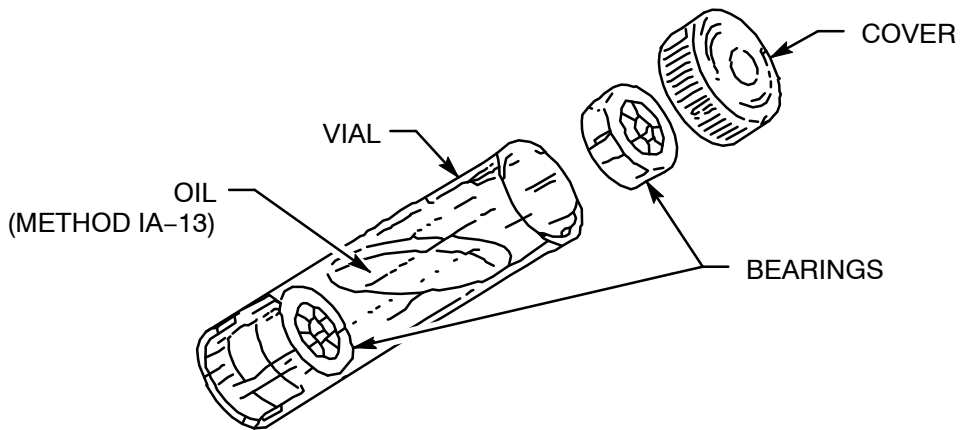

Figure 3. Unit Package – Type 3

P10132-001

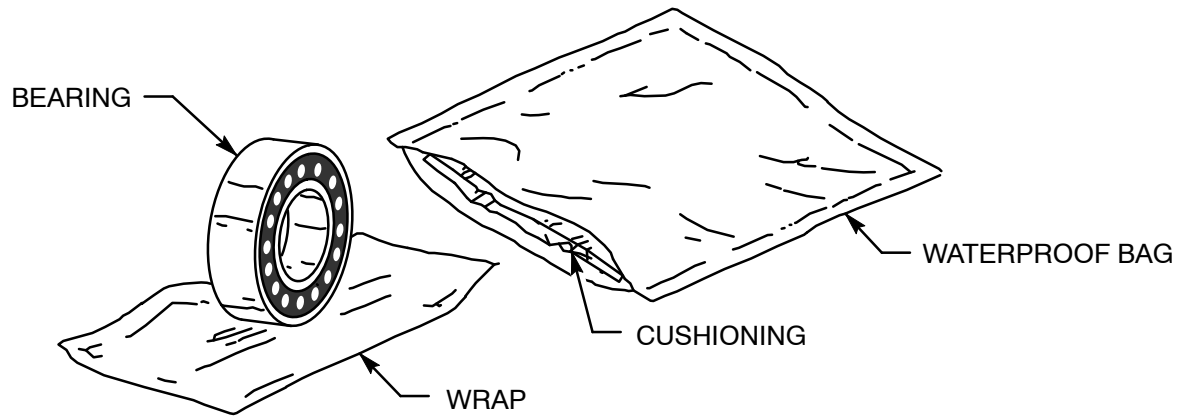

Figure 4. Unit Package – Type 4