

---

## IDENTICAL PARTS INTERLEAVED IN NEUTRAL/GREASEPROOF PAPER/PLACED IN A BOX

---

### **1.0 SCOPE**

This standard provides a method for the packaging of multiple items within a box, separated by interleaving material.

### **2.0 REFERENCES**

- 2.1 Lockheed Packaging Standard LPS 40-0001
- 2.2 NAS Packaging Standard NAS 3442

### **3.0 REQUIREMENTS**

#### **3.1 GENERAL**

- 3.1.1 Unless otherwise specified, the quantity per unit package shall be in accordance with the contractual document.
- 3.1.2 Material used for interleaving shall not degrade or cause commodity deterioration during shipment or storage.
- 3.1.3 Items coated with lubricants, transferable film or other coatings which may be absorbed through wicking action shall be interleaved with greaseproof/plastic material.
- 3.1.4 The interleaving material shall completely cover the item(s) to avoid any metal-to-metal, et al., contact.
- 3.1.5 Exposed silver or silver-plated parts shall be protected with tarnish-inhibitor material. Minimum surface area of the tarnish inhibitor shall be twice the area of the silver surface of the item.

**NOTE:** The treated side of the inhibitor material must be facing the item.

**CAUTION:** ITEMS HAVING ANY SURFACES INCOMPATIBLE WITH THE TARNISH INHIBITOR SHALL BE COMPLETELY WRAPPED WITH A NEUTRAL MATERIAL PRIOR TO APPLICATION.

- 3.1.6 Tarnish inhibitor may be adjacent to but shall not be allowed to come in contact with chemically finished surfaces such as anodize, iridite, chromate coatings and other nonferrous metals (e.g., cadmium, copper and brass).
- 3.1.7 The interleaving method may be accomplished by individual cut sheets interleaved between each item (Figure 1), or with a single sheet interleaved between item(s) (Figure 2).

#### **3.2 UNIT PACKAGE**

- 3.2.1 Protect items in accordance with Paragraph 3.1.7.
- 3.2.2 Interleaved items may be bundled in multiple uniform quantities and secured with tape.
- 3.2.3 Insert items into appropriate size and type of container(s) to protect items during handling/shipment (Figure 1 and Figure 2).
- 3.2.4 Fill all voids with suitable dunnage.

#### **3.3 INTERMEDIATE PACKAGING** – (Consolidation of unit packages, when applicable)

- 3.3.1 Unless otherwise specified, the number of unit packages per intermediate container (containing identical parts) shall be limited to the dimensions and gross weight provisions of the container specification (Ref Carrier Regulations).
- 3.3.2 Fill all voids with suitable dunnage, blocking or bracing, to prevent damage during handling/shipment.

#### **3.4 PACKING**

- 3.4.1 Pack appropriate number of intermediate containers uniformly into each shipping container.

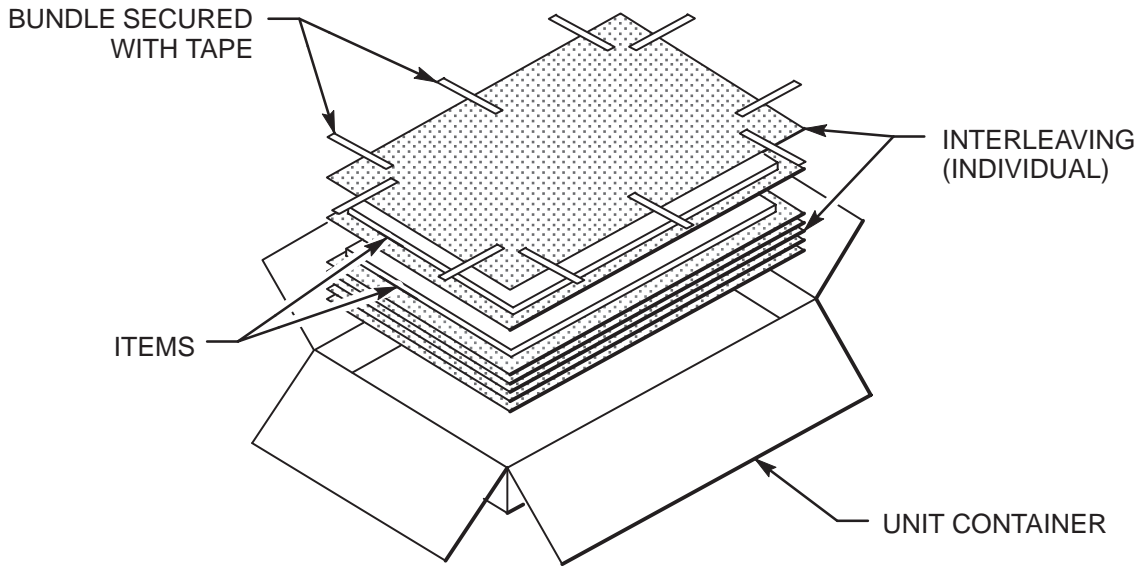

Figure 1. Items with Individual Interleaving

P10057-001

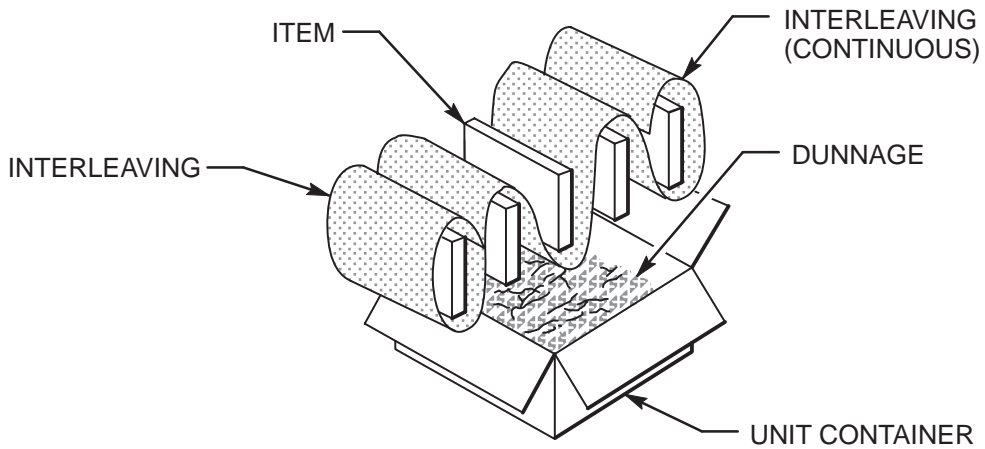

Figure 2. Items with Continuous Interleaving

P10058-001

- 3.4.2 Shipping containers as packed, shall protect the item from damage during ordinary handling/shipping and shall meet the minimum requirements of common carriers for safe transportation at the lowest rate to the point of delivery (see contractual document).
- 3.4.3 Unit or intermediate containers which meet the requirements of Paragraph 3.4.2 may be used as shipping containers.
- 3.4.4 Enclose or attach a copy of packing slip to the shipping container.

### 3.5 MARKING

- 3.5.1 Unit Package Marking – Label or mark each package to show at least the part number per contracting document, quantity and supplier identity. Packages containing tarnish inhibitor shall be marked/labeled: “Protected with Tarnish Inhibitor – Do Not Open Until Ready for Use or Inspection.” Additional markings may be specified in the item detail specification or drawing.
- 3.5.2 Intermediate Packaging Marking – Label or mark each container to show at least part number per contracting document, supplier and quantity of parts.
- 3.5.3 Shipping Container Marking – Label or mark each container to show part number per contracting document, the LMSC contracting document number, supplier, destination and quantity of parts.
- 3.5.4 Apply special handling and precautionary markings as required.

### **4.0 QUALITY ASSURANCE**

- 4.1 Packaging shall be accomplished in such a manner as to prevent physical damage to, or degradation of, the packaged items during delivery to the using activity. It shall be the prerogative of LMSC to return damaged items, at supplier’s expense, when such damage is attributable to improper or inadequate protection.

### **5.0 NOTES**

- 5.1 The following information is intended as a guide or aid to suppliers in meeting the requirements of this specification.
  - 5.1.1 DEFINITION – Unprotected Silver Surfaces. All metallic silver surfaces (having stringent reflectivity or conductivity requirements, close-tolerance finishes and/or dimensions, without supplementary tarnish-resistant treatment), the deterioration of which may result in premature failure or malfunction of the item or equipment having such surfaces.
  - 5.1.2 REFERENCES

<b><u>Commodity</u></b>	<b><u>Military/Commercial Specification</u></b>
Box Material, Waterproof	PPP-B-1055 (Flexible)
Box, Corrugated	PPP-B-636
Box, Folding	PPP-B-566
Box, Metal-Stayed	PPP-B-665
Box, Setup	PPP-B-676
Corrugation, Flexible	PPP-B-291
Cushioning, Cellulosic	PPP-C-843
Cushioning, Flexible Plastic	PPP-C-795
Cushioning, Free Flow	MIL-C-23734
Fiberboard, Corrugated	PPP-F-320
Paper, Neutral	MIL-P-17667
Sheet, Plastic	L-P-378, Type I (Flexible)
Tarnish Inhibitor	“Silver-Saver” – Daubert Chemical Co., Oakbrook, IL