

SERVICE NEWS



***T56 Oil System
Maintenance***

Lockheed SERVICE NEWS

A SERVICE PUBLICATION OF
LOCKHEED AERONAUTICAL
SYSTEMS COMPANY

Editor

Charles 1. Gale

Art Director

Anne G. Anderson

Vol. 18, No. 3, July-September 1981

CONTENTS

- 2 **Focal Point**
Jim Stewart,
Subcontracts Administrator
Subcontracts and Machined Parts
Department
- 3 **T56 Engine Oil System
Maintenance**
A comprehensive guide to engine
oil loss prevention.

Photographic Support: John Rossino

Cover: The first of more than two dozen new C-130 airlifters planned for acquisition by the U.S. Naval Air Reserve, this C-130T has been assigned to recently reactivated VR 54 Squadron. The USNR unit is based at Louisiana's New Orleans Naval Air Station.

The back panel shows another view of VR 54's brand-new Hercules, this time over the Crescent City's famed sports facility, the Louisiana Superdome.

Service News is published by Lockheed Aeronautical Systems Company, a unit of Lockheed Corporation. Information contained in this issue is considered by Lockheed to be accurate and authoritative; it should not be assumed, however, that this material has received approval from any governmental agency or military service unless it is specifically noted. This publication is for planning and information purposes only, and it is not to be construed as authority for making changes on aircraft or equipment, or as superseding any established operational or maintenance procedures or policies. The following marks are registered and owned by Lockheed Corporation: "Lockheed", "Hercules", and "JetStar". Written permission must be obtained from Lockheed Aeronautical Systems Company before republishing any material in this periodical. Address all communications to Editor, Service News, Department 66-14, Zone 0306, Lockheed Aeronautical Systems Company, Marietta, Georgia 30063. Copyright 1981 Lockheed Corporation.

Focal Point



Jim Stewart

A Special Partnership

Allison-manufactured 501/T56 turboprop engines have been used exclusively to power Hercules aircraft from the YC-130 to the aircraft's present configuration, the Advanced C-1 30H. This is neither happenstance nor merely an artifact of previous practice. It is the consequence of a special, ongoing partnership between two companies which occupy unique positions of leadership in the world of aerospace technology.

Allison Gas Turbine Division has worked closely with Lockheed over the years to provide a **power plant whose performance criteria meet all of the mission profile requirements for the various**

C-1 30 and L-1 00 models that have evolved. The result is a quality product that offers a constantly improving record of performance, durability, and efficiency.

This issue of Service News features an article which details proven techniques that maintenance personnel can use in troubleshooting the 501/T56 engine's lubrication system. This valuable guidance from Allison is an example of that company's commitment to working jointly with Lockheed to provide exemplary support for the operation and servicing of its products on Lockheed aircraft.

Allison's commitment to close support of Lockheed products also manifests itself in a very literal way. The engine manufacturer's Southeastern Zone Office is physically located on the grounds of Lockheed's Marietta manufacturing facility. From this vantage point, the Allison team provides 24-hour-a-day direct technical service and product support for Lockheed's Hercules production effort, and for a number of Hercules operators as well.

This kind of close, working partnership makes a difference that counts. It helps transform policy and promises into the kind of solid, hands-on product support whose value can be measured. It is just one more way that we at Lockheed strive to ensure that each and every Lockheed customer realizes the maximum benefit from the quality and capability that is built into every Hercules airlifter.

Sincerely,

James H. Stewart,
Subcontracts Administrator
Subcontracts and Machined Parts Dept.

PRODUCT SUPPORT

LOCKHEED AERONAUTICAL
SYSTEMS COMPANY

H. L. BURNETTE DIRECTOR

FIELD SUPPORT	SUPPLY SUPPORT	TECHNICAL PUBLICATIONS	RM&S DESIGN	CUSTOMER TRAINING
J. D. Adams	J. L. Bailey	A. G. Hunt	H. D. Hall	S. S. Clark



A Guide to Oil Loss Prevention

by Leon D. Smith, *Manager, Southeastern Zone
Allison Gas Turbine Division*

The lubrication system of the Allison 501/T56 engine has proven itself effective and reliable in literally millions of flight hours during more than three decades of service. Like all mechanical systems, however, problems can and do occur. One lubrication system problem that the T56 engine maintainer may encounter sooner or later is unexplained oil loss.

Engine oil loss, excessive consumption, or just plain "dumping" that has no obvious cause can challenge the expertise and test the patience of the most experienced power plant specialist. Furthermore, there are potentially so many factors involved that it is difficult to give advice that will be both general enough to cover all cases and specific enough to be useful. But there are some procedures that should be followed and things to look for that can help. Please note that this discussion is optimized for Allison Series III engines like the 501-D22A and T56-A-15. Older engines, although fundamentally similar, may require some modification of the procedures described.

It is also important to bear in mind that the information contained in this article is not intended to replace currently approved technical data or supplant accepted maintenance procedures. This presentation is merely a compilation of proven maintenance techniques designed to improve the efficiency of your troubleshooting effort. The concepts are based upon the ideas and experiences gained by Allison product support engineers in many years of close collaboration with U.S. military units and other 501/T56 engine maintainers around the world.

System Description

To be able to troubleshoot an oil loss problem efficiently, one must first be thoroughly familiar with the entire engine oil system and know how it works. Most important, the troubleshooter must know what influence each component has on the total system. This includes the nacelle (QEC kit) components as well as the basic engine parts.

The overall 501/T56 engine lubrication system consists of two essentially independent systems (Fig. 1). They are the pressure lubrication system and the dry-sump scavenge recovery system. These two systems, commonly known as the "pressure side" and the "scavenge side," actually have only one thing in common, and

that is the oil they pump. They do share a few mechanical devices, however, which we will describe later on.

Each of the two systems is made up of two subsystems. One is for the reduction gear assembly and the other is for the engine power section. The reduction gear assembly thus has its own pressure system and scavenge system, as does the power section. Although technically separate, the four subsystems do interrelate both systemically and mechanically to one degree or another.

Two independent pressure pumps, one for the reduction gear assembly and one for the power section, move oil from a common oil supply tank through their respective distribution systems and provide lubrication and cooling to the various internal surfaces. Two dry-sump scavenge systems route recovered oil back to the oil tank through a common return system.

On the way back to the supply tank, the oil is filtered and cooled. At this point the oil is a heavily aerated, foamy mixture. When it reaches the tank, the oil is separated from the air it has entrained in its passage through the lubrication system. The oil drains into the tank and the air escapes through the tank pressurizing valve and out the nacelle drain mast to the atmosphere.

A Troubleshooting Overview

When the problem is oil dumping, the pressure sides of these systems can be virtually eliminated as possible sources of the trouble. Remember that the pressure systems supply oil to the engine. When the symptom is dumping, the problem is not that oil is not being supplied, but that it is not being removed from the engine and returned to the tank.

About the only time the pressure side can cause dumping is when one or more of the oil jets have enlarged metering holes. This could allow more oil to flow into the engine than can be pumped out by the scavenge recovery system. This kind of problem does not just "happen," however. It is normally discovered on the first run after an oil jet has been replaced.

Another possibility is that oil is simply leaking from the engine before the scavenge system can recover it. The troubleshooter must remember that every oil dumping case is different. The component that was replaced to correct the most recently encountered oil problem may not be, and probably will not be, the culprit the next time around. Every step in the isolation procedures must be accomplished in each and every case in order to isolate and identify the faulty component.

The reports given by the flight crew are often crucial in getting an investigation off on the right foot. For instance, they may mention that the indication of oil loss

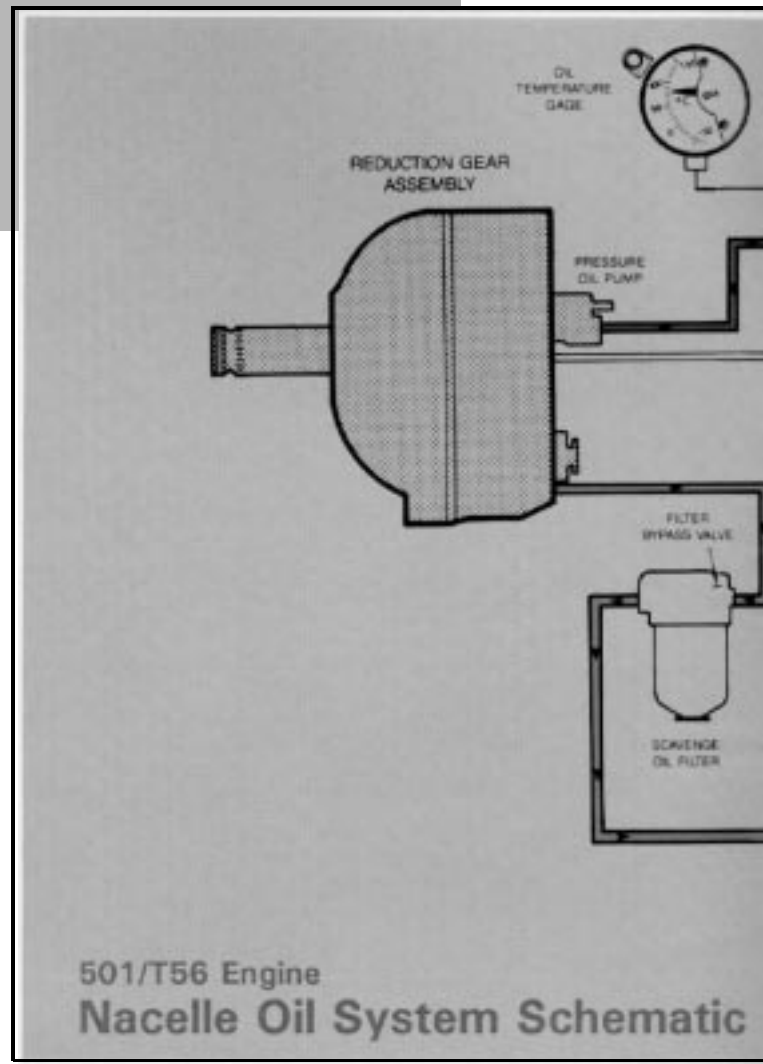
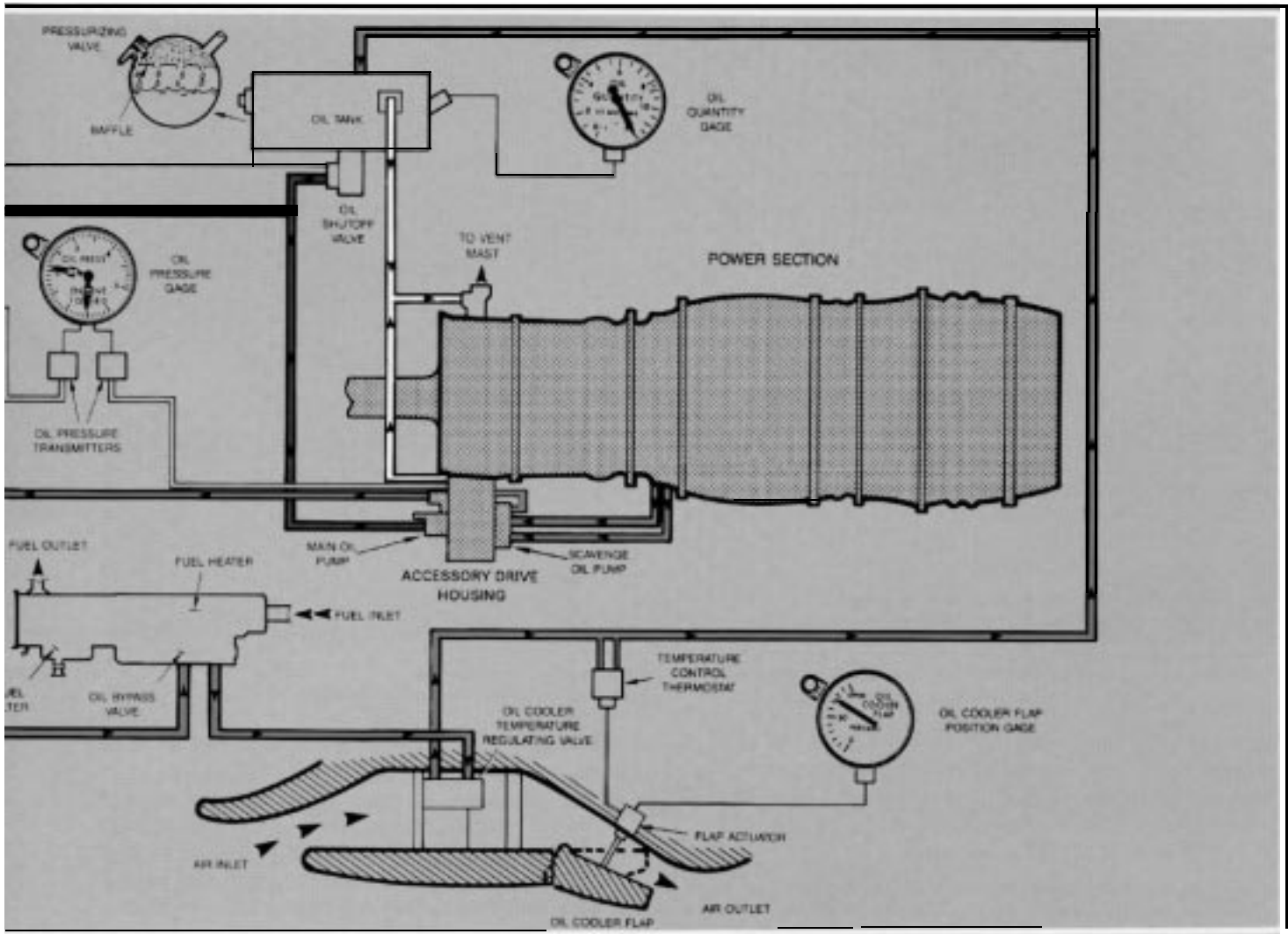

Figure 1.

occurs only at high altitude. Or, that oil dumping occurs only during a nose-up attitude. Here is a list of questions whose answers can be most helpful in isolating the cause of an oil dumping problem.

1. What was the oil consumption rate?
2. Was the oil leak visible to the crew? If so, from where?
3. Was the oil loss evident only at high altitude?
4. At what altitude did the oil dumping occur?
5. After descent, at what altitude did the oil dumping stop?
6. How long into the flight did the dumping begin?
7. What was the aircraft attitude when the dumping began?



8. Did the oil dump begin immediately after initial start up?
9. Does the oil dump while the aircraft is on the ground, as well as in flight?
10. Was there a rise in oil temperature before or during the dumping incident?
11. Did the affected engine require the oil cooler flap to be opened more often than the other engines to maintain proper oil temperature?
12. Was there a noticeable reduction of oil quantity on the oil quantity indicator before the actual dumping began? If so, how much did the quantity drop and how long did it take before the dumping began?

Oil loss, oil consumption, or dumping problems can usually be grouped into three broad areas: static oil leaks, internal leakage, and scavenge system ineffective-

ness. Let us take an in-depth look at each of these categories individually.

Static Oil Leaks

Static oil leaks usually show up after an engine has been sitting unused for a period of time. The period can be anything from a few hours to several days. Note the distinction in terminology between static leaks and internal leakage. Static leaks occur in an engine at rest, while internal leakage shows up only during actual engine operation.

The most common cause of static leakage, also called gravitational flooding, is an improperly functioning oil retention check valve. This may occur either in the power section oil filter assembly or in the reduction gearbox oil pump assembly (Fig. 2).

It should be kept in mind that gravitational flooding can be a transient condition, caused by a particle of foreign material temporarily lodged in the seat of one of

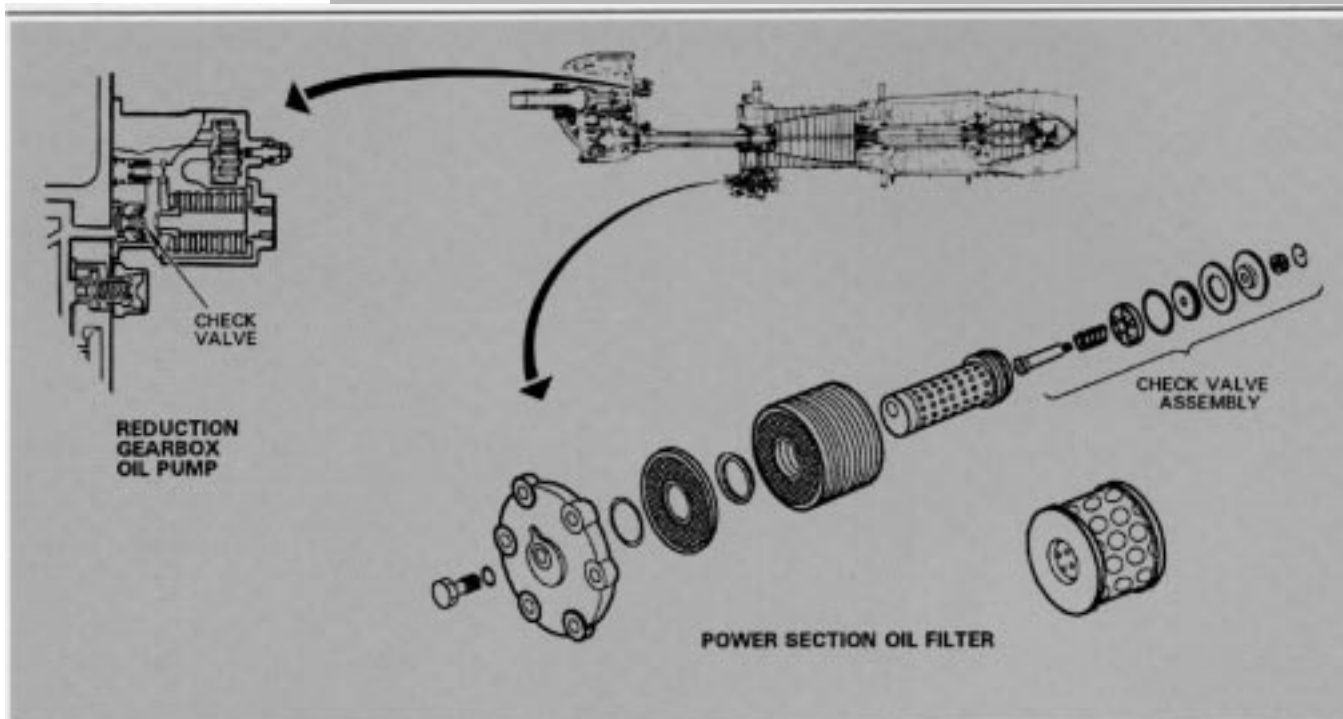

Figure 2. Improperly functioning oil retention check valves are a common cause of static oil leakage.

the oil retention check valves. Sometimes there will be evidence of oil dripping out of the bottom compressor bleed valves, and sometimes there will be oil in the tail pipe or intake. On the other hand, there may be no external indication of oil leakage at all.

When a static leak is suspected, perform the following confirmation check. Verify that the oil quantity gage of the affected engine shows at least four gallons present to provide lubrication, and then motor the engine briefly.

NOTE: Do not add oil to the tank if the oil level is below full, but above four gallons.

If the oil quantity increases significantly during the motoring process, it is likely that an excessive amount of oil has found its way into the sumps and is being scavenged back to the supply tank during the motoring process. We know this problem can be temporary, so if there is no indication that the engine is a repeat offender, it should be run to clear it of foreign material and checked again. The engine will, of course, smoke and vent abnormally during the first few minutes after starting when the sumps have been flooded.

Start the engine in low-speed ground idle. Then close the bleed air valve so that the bleed air from what is probably a well-oiled compressor will not enter the aircraft pneumatic system. Operate the engine at flight idle or higher until the engine is clear of the blue smoke from the residual oil. Note that it is a good idea to compressor-wash the engine before returning it to service to get rid of all the unwanted oil film and avoid

the possibility of fumes entering the air conditioning system.

The oil retention check valves are not always the culprits; there are other components in the system that can cause persistent static oil leaks. One or more of the following components may contribute to the problem:

- Power section oil filter O-ring deteriorated or damaged.
- Power section oil filter check valves not seated.
- Power section oil filter bypass valve not seated properly within the accessory drive housing front cover.
- Power section oil pump pressure regulating valve not seated.
- Power section oil pump pressure regulating valve O-ring at valve outside diameter deteriorated, damaged, or missing.
- Power section oil pump drive and idler shaft seals between the pressure and scavenge pump gears damaged, deteriorated, or missing.
- Reduction gear assembly oil pump check valve not seated.
- Reduction gear assembly oil filter too long, causing oil pump check valve to remain off seat.

- Reduction gear assembly oil pump drive shaft seal deteriorated, damaged, worn, or missing.

If static oil leaks become a persistent problem with a particular engine, further in-depth troubleshooting must be accomplished to identify and correct the malfunctioning component. There are effective isolation procedures in the maintenance manuals which will help you identify and locate the specific causes of static oil leaks. Following through on **these** procedures will solve most static oil loss problems.

Internal Leakage vs. Scavenge Problems

If static leaks can be ruled out as a source of oil loss, which of the remaining choices is it? Internal leakage or an ineffective scavenge system?

When an engine accumulates oil before it dumps, it generally points toward some sort of scavenge problem. There are other situations, however, in which the engine will lose oil but not accumulate it anywhere. If no accumulation has occurred, we know oil *is* being scavenged. In such cases, it is likely that the oil loss is caused by internal leakage somewhere in the power section.

In practice, it is not always easy to distinguish between internal leakage and an ineffective scavenge

Figure 3. Accumulated oil will often collect in one or more of three major areas.

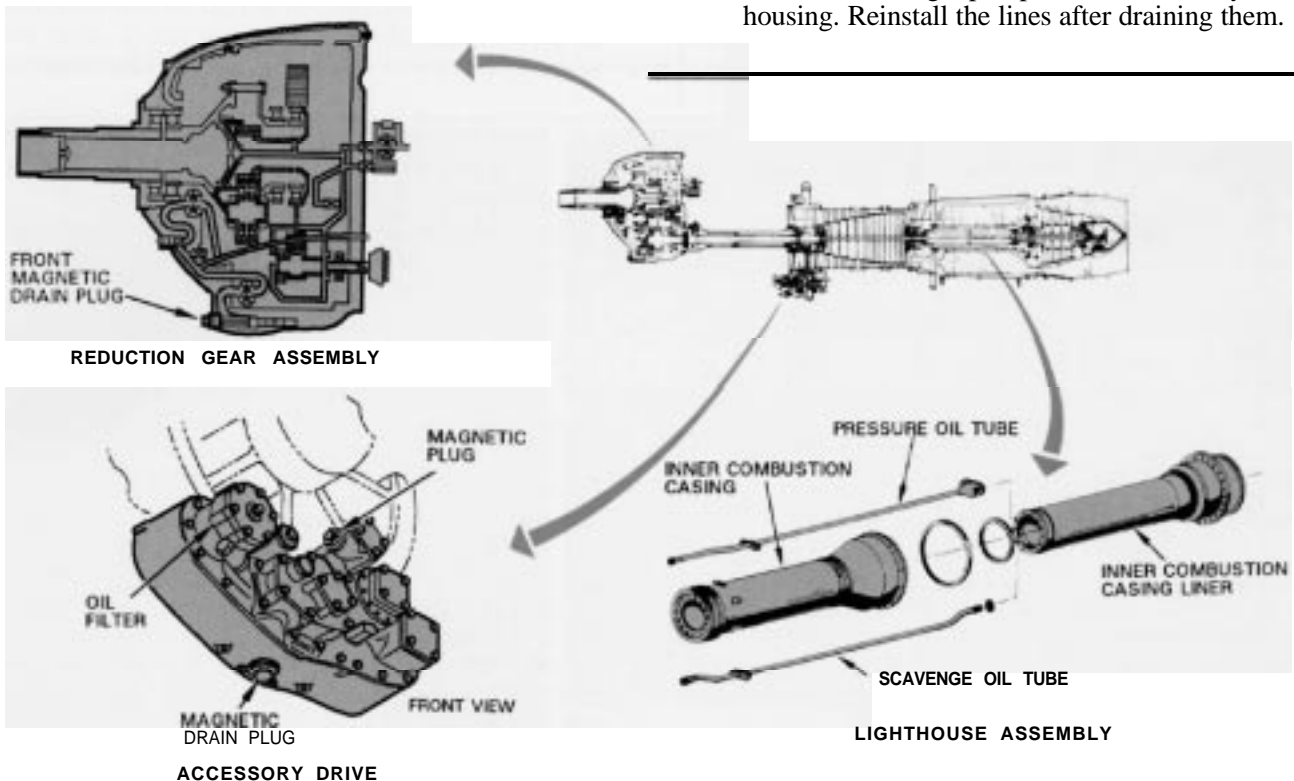

system. When an engine consumes or dumps oil, it will often do so after accumulating oil in one or more of three major areas: (1) the combustion assembly inner casing-the “lighthouse” assembly, (2) the reduction gear assembly, and (3) the accessory drive housing (Fig. 3).

To troubleshoot an oil loss problem effectively, the troubleshooter must first determine whether or not the engine is actually accumulating oil. The following procedure is designed to ascertain if oil is being accumulated, and if so, where.

Creating a ‘Known Condition’

To be able to troubleshoot an engine that may or may not have residual oil throughout the internal cavities, an unknown condition, one must begin the troubleshooting procedures by creating a known condition. Follow the steps of this procedure in sequence. Note that it is a good idea to carry out the following procedure when the oil is at normal operating temperature.

1. Remove the power section accessory drive magnetic drain plug. Drain all of the oil from the accessory drive housing, and then reinstall the plug.
2. Remove the front (lower) magnetic drain plug from the reduction gear assembly. Drain all of the oil from the reduction gear assembly and then reinstall the plug.
3. Remove and drain both scavenge lines supplying the external scavenge pump at the accessory drive housing. Reinstall the lines after draining them.

Note that at this point in the troubleshooting procedure, the amount of oil that drains from these areas is not important. A small amount of static oil leakage at these locations is normal.

- Record, exactly, the amount of oil in the oil tank, using the dipstick. A measured amount of oil is now in the tank, and the reduction gear assembly, accessory drive housing, and lighthouse areas are empty. In other words, a known condition exists.
- Attach both a scavenge back pressure gage and a lighthouse pressure gage to the engine. The scavenge back pressure gage should be connected to a point where "pump out" pressure can be read. One such location is the main pressure scavenge oil pump magnetic plug. To connect to the pump, modify a magnetic drain plug by drilling and tapping a hole in the center for a No. 4 hose fitting.

Another possibility is the external scavenge filter "in" point. Connection to the filter can be made by removing the external filter bypass indicator button and inserting the special adapter provided with the PN 23008696 test set, which is available from Allison. Either of these points will show the back pressure the pump senses during operation. Figure 4 shows the locations referred to in this step.

Lighthouse pressure should be determined by attaching the pressure gage to the engine at the

lighthouse pressure connection on the diffuser case just forward of the 11 o'clock bleed air manifold adapter. The pressure should be read with a gage which indicates inches of mercury (in. Hg).

- Operate the engine at cruise power for a minimum of 30 minutes, or until the oil begins to dump out the drain mast, whichever occurs first. During the run, record the oil scavenge back pressure readings at oil temperatures of 60°C 70°C and 90°C, and peak scavenge back pressure. Record peak lighthouse pressure at a stabilized takeoff power setting.
- Shut the engine down. Measure the quantity of oil remaining in the oil tank. Record the amount the oil level has dropped from the previous measurement.

Remember that if the oil was not at operating temperature when you began the check, it will have expanded because of the increase in temperature. The difference can be up to 2 quarts, depending on how cold the oil was initially. This must be considered when figuring the level reduction on the dip stick. That is why the oil should be at normal operating temperature before carrying out this procedure.

- Within 5 minutes after engine shutdown, remove the magnetic drain plugs from the accessory drive housing and the reduction gear assembly. Catch and measure the amount of oil that drains from these areas separately.

Figure 4. Determine "pump out" pressure at the main oil pump magnetic plug or the external oil filter "in" point, and lighthouse pressure at the pressure connection on the diffuser case.

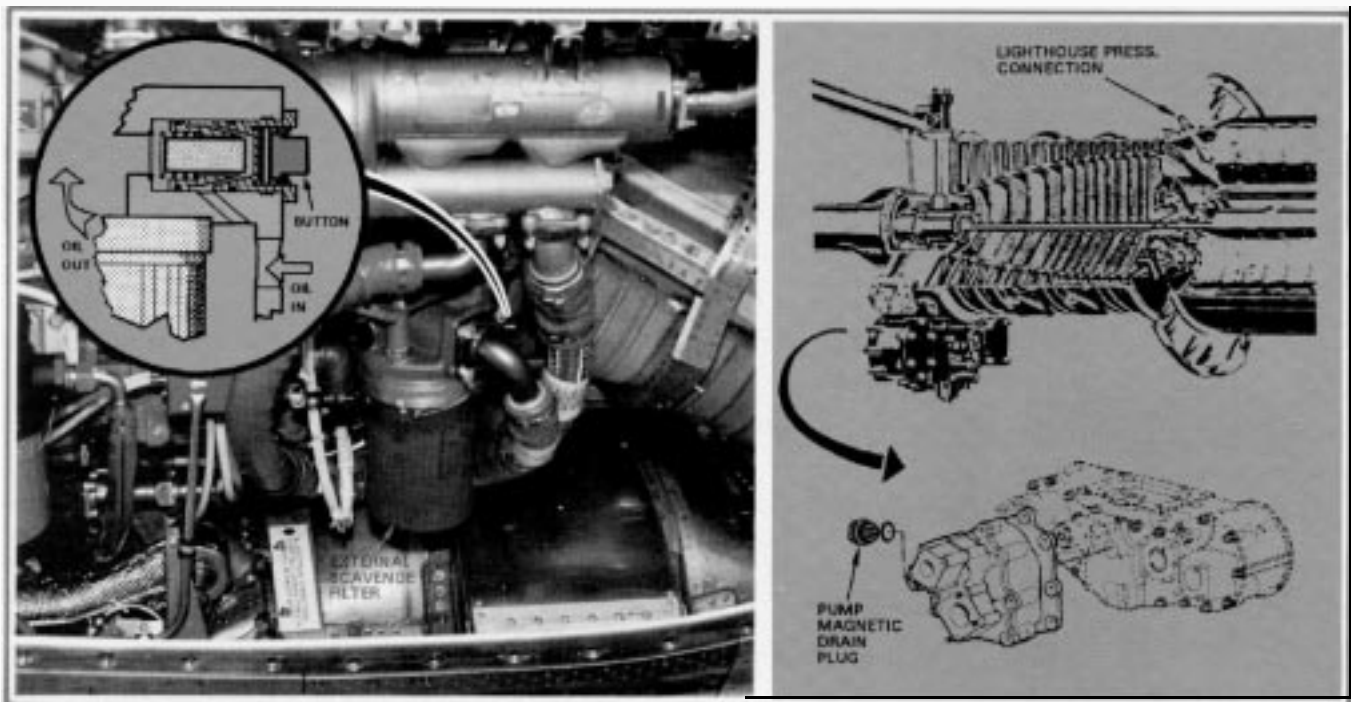

9. Under normal operating conditions, the oil drained from the accessory drive housing should not be more than 1 quart. The oil drained from the reduction gear assembly should not be more than 2.5 quarts. The amount of oil collected over and above these amounts can be considered accumulated oil.

Analyzing the Results

Mathematically determine the sum of the oil drained from both the reduction gear assembly and accessory drive housing. Subtract this total from the original dipstick reading. Taking into account up to 2 quarts for heat expansion of the oil, if applicable, the remainder should equal what was recorded on the dipstick after shutdown.

If the oil reduction on the dipstick was more than the sum of oil collected from the reduction gear assembly and accessory drive housing combined, the remaining oil is probably in the lighthouse assembly. This amount should not be more than 1 pint.

This method is most accurate when very little or no dumping occurred during the run. For this reason it is imperative that the engine be shut down as soon as oil dumping begins.

If lighthouse accumulation is suspected, remove the oil scavenge lines from the external scavenge pump. Catch and measure the amount of oil drained from these two lines. Any amount over 1 pint can be considered oil accumulation. If, by using these procedures, it is determined that 110 oil has accumulated in any of these three major areas, the most probable cause for the oil loss is internal leakage.

Internal Leakage

There is no cut-and-dried method of pinpointing the actual cause of all internal leakage problems without disassembling the engine. However, there are some things that can be done to help isolate the problem areas.

There are several locations where internal leakage most often occurs, all of which are in the power section. Worn or deteriorated O-ring seals, or a worn or damaged compressor front bearing labyrinth seal in the compressor front bearing and extension shaft area can cause internal leakage (Fig. 5).

The lighthouse area can experience internal leakage from either end caused by damaged crush gaskets, worn or damaged labyrinth air or oil seals, or even a crack in one of the combustion chamber inner liners. The turbine rear bearing sump area can suffer leakage because of ineffective crush gaskets, turbine rear scavenge pump failure, or a worn or damaged turbine rear bearing labyrinth seal (Fig. 6).

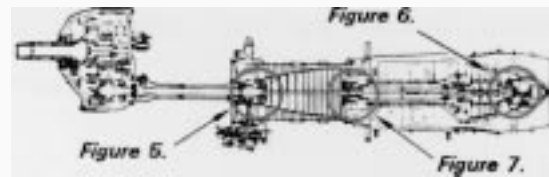

Three common locations for internal leakage are shown below.

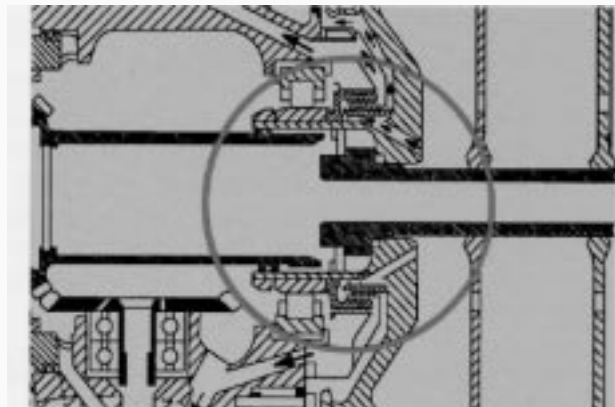

Figure 5 Compressor front bearing labyrinth seal.

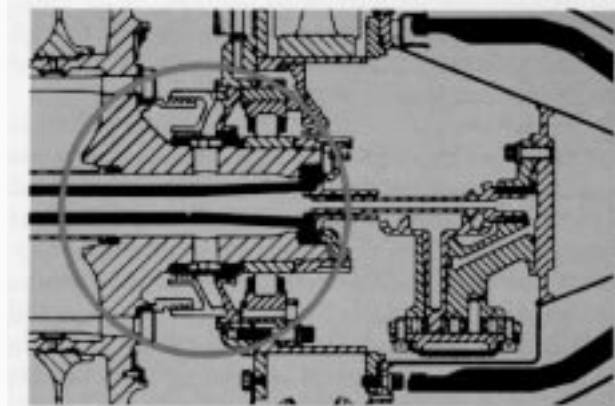

Figure 6. Turbine rear bearing labyrinth seal.

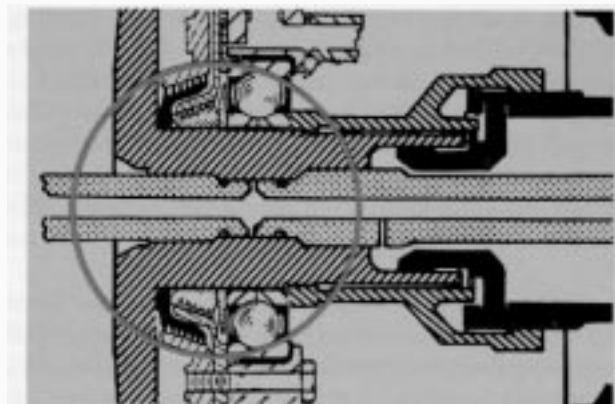

Figure 7. Compressor rear bearing labyrinth seal.

One tool that can aid in the process of elimination is the lighthouse pressure gage. By combining the lighthouse pressure indications with physical evidence of an oil leak, one can determine which part of the lighthouse area is at fault.

For example, if the **lighthouse pressure** is over 11 in. Hg, coupled with evidence of oil loss, the most probable cause is an ineffective compressor rear bearing labyrinth air seal (Fig. 7). This is due to the lighthouse being overpressurized by compressor discharge air flowing over the worn or damaged labyrinth air seal.

This overpressurization forces the oil in the turbine front bearing area to flow over its labyrinth seal and out the exhaust. Remember, each of these labyrinth seals is a dual-stage seal. They are made **up** of an air seal and an oil seal combined in one seal assembly. It is therefore possible for only one part of the seal to be a problem while the other part is still serviceable.

The reverse can also take place. The turbine front bearing labyrinth air seal could be damaged or worn, causing an overpressurization of the lighthouse assembly. This will force the oil in the compressor rear bearing sump out through its oil seal and out its vents. However, the indication of this problem would be high lighthouse pressure coupled with oil venting from the compressor rear bearing vents.

What can make troubleshooting this area even more confusing is that oil can vent out the turbine exhaust area when only the turbine front bearing oil seal is worn or damaged. This, however, produces a different symptom, in that the oil will be lost even though lighthouse pressure remains normal. This happens because the oil seal is worn or damaged, and the oil can flow across this seal and out the exhaust. There is no cause for the lighthouse pressure to build up.

To complicate things still further, the reverse can happen as well. Oil can dump out of the compressor rear bearing vents because the compressor rear bearing labyrinth oil seal is worn or damaged. The oil simply flows across the bad seal and out the vents. There is again no reason for lighthouse pressure to build. The external symptom seen in this case is oil dumping out of the compressor vents, with the lighthouse pressure normal. Table 1 at the right may make all this a little easier to understand.

If there is evidence of oil coming from the three o'clock and nine o'clock turbine inlet struts, the problem is probably the inner combustion liner crush gaskets. To correct this problem, replace the gaskets and use the following torquing procedures. Tighten the bolts in order around the circumference until the required torque is obtained. Allow the bolt tension to stress-relieve for 15 or 20 minutes.

Now check the torque again. If there is torque wrench movement, retorque again and wait. Repeat the process until no movement of the wrench occurs when rechecking torque. This procedure ensures a complete crush effect on the gaskets and usually corrects the leakage problem.

If the lighthouse pressure was below 11 in. Hg and no evidence of oil leakage from the compressor vents was noted, try the following:

1. Check the turbine exhaust area for evidence of oil leakage. If oil is present, investigate the turbine rear bearing area. It should be noted that there can be evidence of oil in this area caused by excessive down-the-shaft venting. This condition is most oftencoupled with high lighthouse pressure, but it is possible for it to occur with normal lighthouse pressure as well.
2. Remove and inspect a compressor bleed valve for evidence of oil film. Check for oil in the air inlet housing area. If oil is present in either of these areas, the most probable cause is leakage from the compressor extension shaft housing O-ring or the front compressor labyrinth seal.

Scavenge System Problems

If it is determined that oil has accumulated in one of the three major areas, the problem is likely being caused

Table 1.

11 in. Hg Lighthouse Pressure	Oil from Compressor Vents	Probable Cause
At or above	No	Compressor rear labyrinth air seal.
At or above	Yes	Turbine front labyrinth air seal.
Below	No	Turbine front labyrinth oil seal.
Below	Yes	Compressor rear labyrinth oil seal.
At or above	No	Cracked diffuser, inner combustion liner, crush gaskets, piston rings, or both compressor rear & turbine front labyrinth air seals. Potential problem, needs repair.

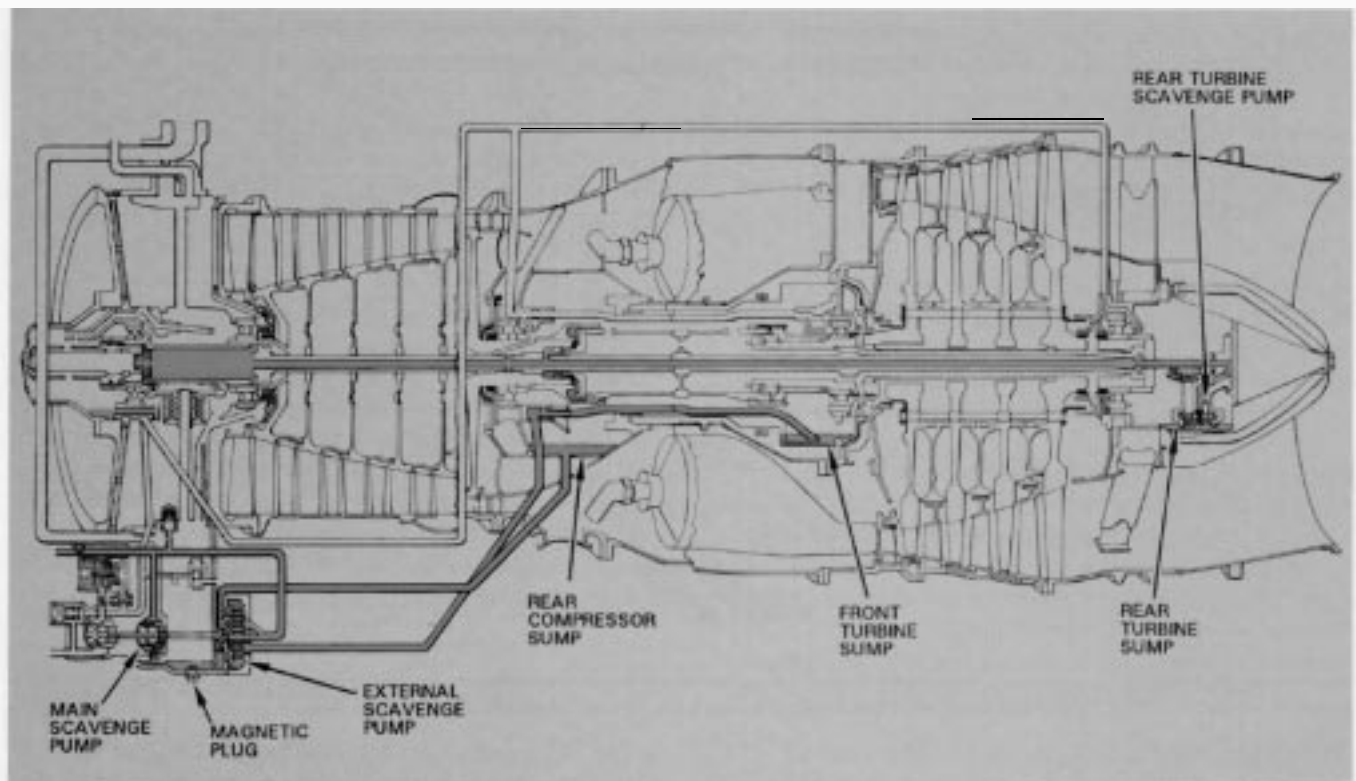

Figure 8. Power section scavenge problems can often be traced to ineffective pumps, leaking seals, and restricted scavenge oil tubes.

by an ineffective scavenge system. The following procedures can help isolate the cause. Note that these actions should be taken only if accumulation was evident in the area under discussion. Each of the three major areas will be addressed separately. Figures 8 and 10 will be helpful in tracing the oil flow in the power section and reduction gear assembly scavenge systems.

Lighthouse Accumulation

There is just one reason why oil accumulation occurs in the lighthouse assembly. That is that oil is being pumped into the lighthouse faster than it is being pumped out. Either there is too much oil being pumped in, which is usually caused by enlarged jets, or the oil is not being removed as fast as it should be. As noted earlier, the latter situation is much more common than the former.

There are several reasons why the oil may not be getting pumped out at a sufficient rate. The most obvious is that the external scavenge pump is not pumping effectively. One possible cause is that the drive shaft is sheared and the pump does not pump at all. Normally when this happens, the lighthouse area fills with oil in a matter of minutes and oil dumps out the compressor rear bearing seal vents, the turbine exhaust, or anywhere else it can get out.

Another reason for **external** scavenge pump ineffectiveness is that the pump is worn to the point where it

cannot keep up with the demand. In the early stages, this usually causes oil loss only at altitude. If not corrected, however, the pump will wear to the point of also being ineffective on the ground.

It should be kept in mind that even a normally operating scavenge pump loses effectiveness at high altitude. At sea level, the oil is being forced into the pump by 14.7 psi atmospheric pressure (on a standard day). This provides a sort of preload effect. At altitude, this pressure is reduced, causing more air and less oil to be pumped. The higher the altitude, the greater the ratio of air to oil becomes. At cruise altitude, a perfectly good scavenge pump actually pumps more air than oil.

All too often, an external scavenge pump is replaced because it is thought to be worn, when in fact it only has a leaking O-ring. The inner O-ring on the pump cover, if leaking, can cause one element of the pump to cavitate. This causes the pump to lose its efficiency (see Fig. 11 on page 15).

Still another reason why oil may not be pumped out fast enough is that the oil is not reaching the pump to be pumped. Remember that this is a suction-feed pumping system. Any restriction in the passages to the pump will cause oil accumulation to begin.

There are two causes of restricted scavenge oil tubes. One is carbon. When oil gets overheated, it tends

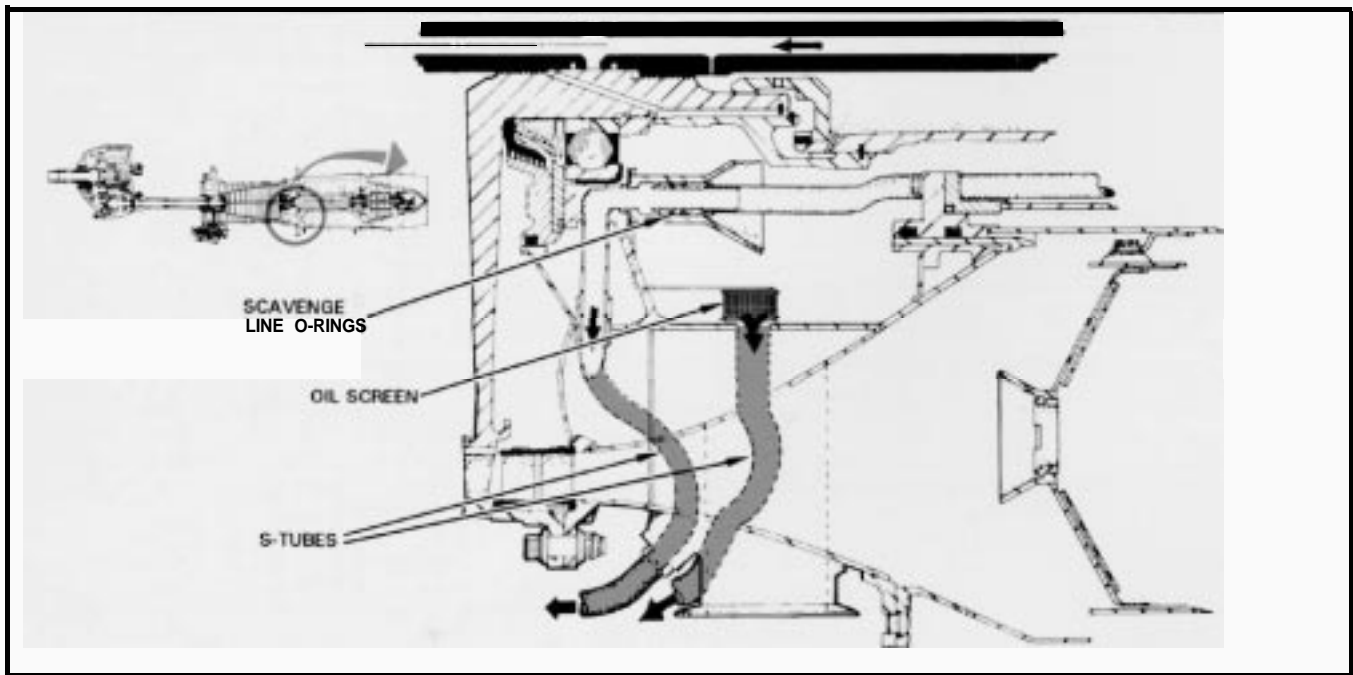

Figure 9. Good seals, unobstructed lines, and undamaged S-tubes are critical to proper scavenge oil flow.

to break down chemically, leaving a carbon residue. The residue can collect in the oil tubes and passages and create restrictions to flow. There is a screen in the bottom of the compressor rear bearing sump to prevent large pieces of carbon from entering the oil tube, but this does not stop carbon from forming within the tubes themselves. Figure 9 shows the details of several of the components discussed on this page.

The other cause for restricted oil tubes is air. Air is not really a restriction, but it can act to inhibit flow. Leaking scavenge line packings at the diffuser port connection allows lighthouse pressure to enter the oil tube. This breaks the suction to the turbine front bearing sump. There are two O-rings installed on the return scavenge line to help prevent this from happening.

Another place air can enter the system is at the diffuser S-tubes. These tubes are located inside the diffuser 5 o'clock and 7 o'clock struts. They serve as oil passageways to transfer the oil from the lighthouse area through the compressor air stream to the pump. If one of these tubes becomes cracked, compressor discharge air can enter the tube. The air pressure acts to break the suction and thus inhibits the free flow of oil to the pump.

There is one rather peculiar possibility that should be considered when cracked S-tubes are suspected. Just what happens depends on the severity of the crack. The key symptom is that the oil quantity will drop by approximately 2 to 3 gallons when the engine is running above low-speed ground idle. The lost oil will then be mysteriously recovered when the engine is "down-shifted" to low-speed ground idle.

The key here is the fact that the oil quantity returns to normal at low-speed ground idle. To explain further: in low-speed ground idle, the compressor discharge air is sometimes not hot enough, nor at high enough pressure, to expand a hairline crack and force its way into the S-tube, where it can affect the suction of the pump. The pump therefore functions correctly and the oil is properly scavenged back to the supply tank.

When the engine is upshifted or taken to power, the compressor discharge temperature increases, as does the air pressure. This tends to open the crack and allow the now much higher compressor discharge **pressure** into the system, breaking the suction. The oil that is being pumped into the lighthouse area will now no longer be removed as rapidly as it should be, and oil accumulates in the lighthouse assembly as a result.

This causes the oil quantity indicator to show a reduction in oil quantity. When the engine is again down-shifted to low-speed ground idle, the crack will close and the oil that has accumulated in the lighthouse will be scavenged back to the tank. The oil quantity indicator will now show that the oil has returned.

So when an engine tends to "hide" approximately 2 to 3 gallons of oil and then give it back at low-speed ground idle, it is likely that an S-tube in the diffuser is cracked. One way to confirm this problem is to remove the lower bleed air duct from the diffuser and inspect the oil tubes for visible oil seepage. Normally, this area is bone-dry. If these tubes are cracked, there will be signs of an oil film residue or even just wetness around the S-tube area.

If a condition of oil accumulation in the lighthouse is neglected long enough, the lighthouse becomes completely filled with oil. The labyrinth seals will then usually allow the oil to dump, or the oil will pass through the shaft venting system into the rear turbine exhaust area. So, if oil is found in the turbine exhaust area, and more than 1 pint of oil was drained from the lighthouse oil tubes, the problem is likely to be inadequate lighthouse scavenge and not turbine rear bearing seals.

Note that it is not a good idea to allow large amounts of oil to accumulate in the lighthouse. When oil is properly scavenged from this area, it takes heat with it. This is how the compressor rear bearing and turbine front bearing remain cool. If the oil remains, so does the heat. This sets up a condition which promotes premature bearing failure and carbon build-up in the scavenge lines. Keep in mind that these things can happen even with the scavenge back pressure readings well within normal limits.

Reduction Gear Assembly Accumulation

Just as in the case of the lighthouse assembly, there is only one reason why oil accumulates in the reduction gear assembly. That is that oil is being pumped into the reduction gear assembly at a significantly faster rate than it is being pumped out. The reason that the oil is not being removed rapidly enough is usually an inefficient scavenge pump.

Remember that the reduction gear assembly has two scavenge pumps (Fig. 10). One pump, the main scavenge pump, scavenges oil from the sump behind the main diaphragm. The other, the nose scavenge pump, scavenges oil from forward of the main diaphragm. There are two pumps because it requires two pumps to scavenge all of the oil effectively at altitude.

If both pumps fail, or either one fails at altitude, the oil will accumulate in both sumps and begin to fill the reduction gear assembly. When the oil level begins to increase, the oil will usually flow out through the torque-meter and into the compressor front bearing area.

Keep in mind that the compressor front bearing area is scavenged through the accessory drive housing by the power section main pressure scavenge pump. Extra oil flowing into the area will overload this pump, causing accumulation to begin in the accessory drive housing as well. Eventually the oil blows by the compressor front bearing labyrinth seal into the compressor air flow or out the breather vent line to the drain mast, or both.

To the troubleshooter, the key to this condition is the large amounts of oil that will be collected from both the reduction gear assembly and the accessory drive housing magnetic drain plug areas. Also, if one pump has failed, the oil quantity indicator will show a reduction of oil quantity at cruising altitude, but remain relatively stable at lower altitudes.

Figure 70. Effective reduction gearbox scavenging at altitude depends on efficient operation of both nose and main scavenge pumps.

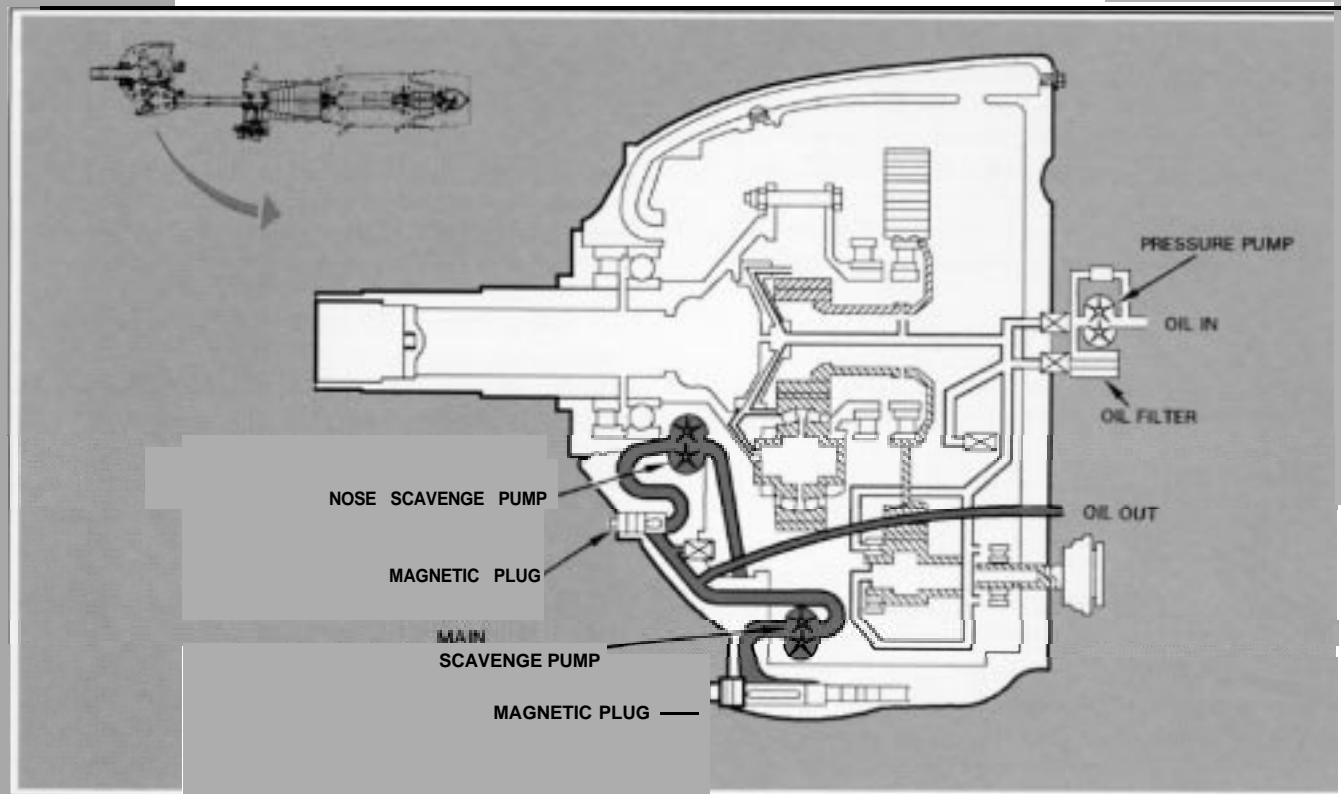

This occurs because one pump cannot keep up with the oil flow at altitude and oil accumulates. The single good pump may be able to prevent further accumulation at lower altitudes, but it does not have enough capacity to completely recover the oil that has been accumulated at altitude. The oil simply stops accumulating.

One symptom which is unique to reduction gearbox main scavenge pump failure is that the engine dumps oil or indicates a reduction of oil quantity only when the aircraft is in a nose-up attitude or during rapid acceleration. It is under these conditions that oil normally scavenged by the nose scavenge pump flows to the rear of the reduction gear assembly.

If the main pump is functioning properly, this extra oil can be pumped back to the tank at low altitudes, such as during takeoff. However, if the main pump has failed, the oil will accumulate and eventually dump into the compressor front bearing area. So, if the engine dumps oil only in a nose-up attitude, especially during takeoff, the reduction gear assembly main scavenge pump should be suspected.

On the other hand, if the engine dumps oil shortly after a long descent, the probable cause is failure of the nose scavenge pump. In a nose-down attitude, the oil that is usually pumped by the main scavenge pump flows to the front of the reduction gear assembly. The nose scavenge pump will usually pump the additional oil back to the supply tank at lower altitudes. However, if the nose pump has failed, oil will accumulate in the front of the reduction gear assembly.

After a time during long descents, the oil quantity indicator will indicate a decrease in oil quantity in the tank. When the aircraft levels off, the accumulated oil flows to the main pump, which usually pumps most of it back to the tank. The oil quantity then partially recovers. The reason the main pump can handle the extra oil at this point is that after a long descent, the aircraft has come to a lower altitude and the pump is more efficient than at cruise altitudes.

Sometimes, during extremely long descents, there is so much oil accumulation that after leveling off, the main oil pump cannot handle the added oil. In this case, the oil again flows out through the torque meter and dumps overboard. A uniqueness about this situation is that the oil will dump for a brief period of time after leveling off, then stop.

The reason for this is that only the excess oil that the main scavenge pump could not pump is being dumped overboard. As soon as the excess oil is dumped, the system returns to the situation where the main scavenge pump is carrying the load of both pumps. And again, since the aircraft is usually at a much lower altitude after a long descent, the pump will be more effective and able

to handle the added load. **Troubleshooters** should again keep in mind that once again, all these things can happen with the lighthouse pressure and scavenge back pressure still within prescribed limits.

There is one other condition that causes reduction gear assembly scavenge pumps to be ineffective, and that is a restriction in the common return system. Remember that the **reduction gear assembly** and power section share the same return system from the external scavenge filter all the way to the oil tank. Any restriction to the free flow of oil in this system will create a back pressure problem for the pumps, which results in a decrease in their effectiveness.

Two indications commonly reveal the presence of this situation. One is that the problem will normally be shown on the scavenge back pressure gage as more than 30 psi back pressure. The other is that both the reduction gear assembly and the accessory drive housing will usually accumulate oil simultaneously. Isolation of the causes of oil return system components failure is covered under "Excessive Scavenge Back Pressure" on page 15.

Accessory Drive Housing Accumulation

Probably the most common area for 501/T56 oil accumulation is in the accessory drive housing (Fig. 11). There are two pumps located in the accessory drive housing, but one, the external scavenge pump, only services the lighthouse area and does not affect the scavenging of the accessory drive housing itself.

The reason for oil accumulation here is the same as in the other cases we have discussed: more oil is being pumped in than can be pumped out. There are several possible causes for this problem. One is a plugged back vent on the main oil pump (Fig. 11). When the back vent becomes plugged, the scavenge element of the pump tends to cavitate, especially at high altitudes. This reduces the pump's effectiveness and oil begins to accumulate inside the accessory drive housing.

Another cause for main oil pump inefficiency can be found within the pump itself. Both the pressure element and the scavenge element share the same drive shaft. If the shaft seal between the two elements wears abnormally, oil from the pressure element begins to flow to the scavenge element. Unfortunately, the scavenge element is not capable of pumping both the scavenge oil and the additional oil from the pressure side.

In this case, the scavenge pump is working to its maximum capacity, but oil is still not being pumped out of the accessory drive housing fast enough. The result is that the accessory drive housing fills with oil, and eventually an oil dumping situation arises. In this case, oil will usually dump when the aircraft is on the ground as well as at altitude.

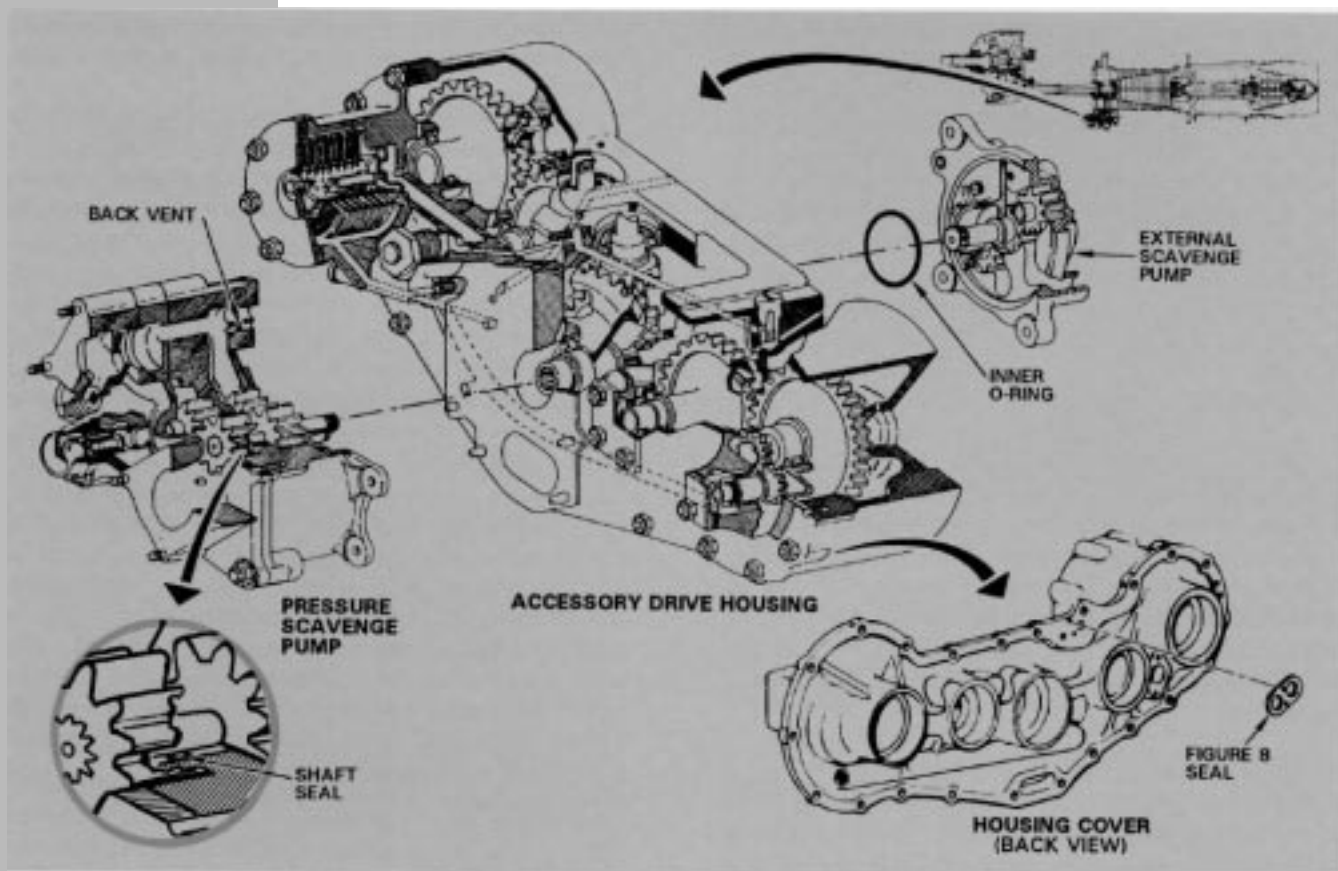

Figure 11. Accessory drive housing oil accumulation is often caused by wear, obstructions, or seal problems affecting the main pressure scavenge pump.

Another internal problem with the pump is that the main oil pump can become worn to the point where it is no longer effective. When this occurs, the problem is usually first indicated by oil dumping at altitude only. As we have seen, a scavenge pump normally becomes less effective at higher altitudes. A worn pump will be most noticeable at these altitudes first. The main oil pump differs from the external scavenge pump in that when the drive shaft shears, both the scavenge and pressure pumps stop working. In this situation, there will be no oil pressure indication on the flight deck.

One more thing to remember about accessory drive housing oil accumulation is the possibility of the “figure 8” seal causing the problem (Fig. 11). Oil from the external scavenge pump flows through one side of this seal and oil from the pressure pump flows through the other side. If either of these seal sides leak, the oil from the leak will flow to the bottom of the accessory drive housing. This creates a reservoir too large for the scavenge pump to handle and accumulation begins.

It is worth repeating that all these things can happen and the scavenge back pressure and lighthouse pressure still be within prescribed limits. However, excessive scavenge back pressure can, and often does, cause oil accumulation in the accessory drive housing.

Excessive Scavenge Back Pressure

Excessive scavenge back pressure is probably the most common cause of oil accumulation. Unfortunately, this can be a rather complex subject. There are many factors, acting singly or in concert, that can lead to back-pressure problems.

The oil flowing back to the oil tank in the 501/T56 oil system has much in common with water flowing through a garden hose. If you squeeze a garden hose with a pair of pliers at its midpoint, the flow to the outlet decreases, and the pressure above the restriction increases. This is the key point for troubleshooters to remember. The pressure inside the hose will increase only on the upstream side of the pliers, between the pliers and the faucet.

This fact of fluid dynamics holds true for the 501-IT56 oil return system as well. Any restriction between the pump and the oil tank will cause a decrease in the flow of oil to the tank, and an increase in pressure on the upstream side of the restriction; in other words, between the restriction and the pump. Such restrictions have to be dealt with; the good news is that we can use this increased pressure as a troubleshooting aid to find where the restriction is located in the system.

Remember that we are not directly concerned with the pressure itself, but with what is causing the increased pressure. When the flow of oil to the oil tank is reduced, the oil must go somewhere else. This is how oil accumulation in all three major areas can begin.

The common scavenge return system has some built-in restrictions (Fig. 12). For example, the external oil filter creates a certain amount of back pressure, depending on how contaminated it is. The more contamination, the more force required to push the oil through the filter.

Other components also contribute to system back pressure. As oil flows through the fuel heater, the requirement for pressure increases, depending on how restricted the cooler core has become. When the oil becomes hot enough to flow through the oil cooler, additional energy is again required, this time to push the oil through the core. The result is another increase in pressure. The exact amount of increase depends on just how contaminated the oil cooler has become. There are many variables to contend with when troubleshooting this system.

We also must not lose sight of the fact that the entire system has to be held under a maximum pressure of 30 psi for the pumps to pump against. The total system back pressure represents the sum of the pressure increases caused by each component's resistance to oil flow all along the way. The significance of this cumulative effect cannot be overstated. If each individual component in the oil return system were to offer its maximum allow-

able flow resistance, the combined total would push the back pressure beyond the overall 30 psi maximum.

If the scavenge back pressure is shown to be above 30 psi, it becomes a matter of finding the location of the restriction that is forcing the system pressure to above-normal levels. This can be somewhat involved because the cause may not be just one component. Quite possibly, problems in two or more units may be involved. The main thing for troubleshooters to remember is to try to get the scavenge back pressure as far below 30 psi as possible. Note that it will be very unusual to get the total pressure below about 20 psi, so there is little point in devoting a lot of effort to trying to get it lower than somewhere in the 20 psi to 25 psi range.

On the other hand, if a troubleshooter takes only enough action to reduce the total pressure to about 29 psi, the problem will return when the total system contamination level pushes the oil pressure up only 1 or 2 psi; in other words, to the dumping threshold. The lower the scavenge back pressure, the longer it will take typical contamination processes to raise the pressure to the dumping stage. In the interest of preventive maintenance, it always makes good sense to keep the total overall scavenge back pressure as low as possible.

Using the Test Set

The Allison PN 23008696 test set has been designed to check scavenge oil pressures at four locations in the oil return system. These key locations are the external

Figure 12. Nacelle-mounted oil system components such as the oil cooler, fuel heater, and external scavenge oil filter are important contributors to scavenge system back pressure.

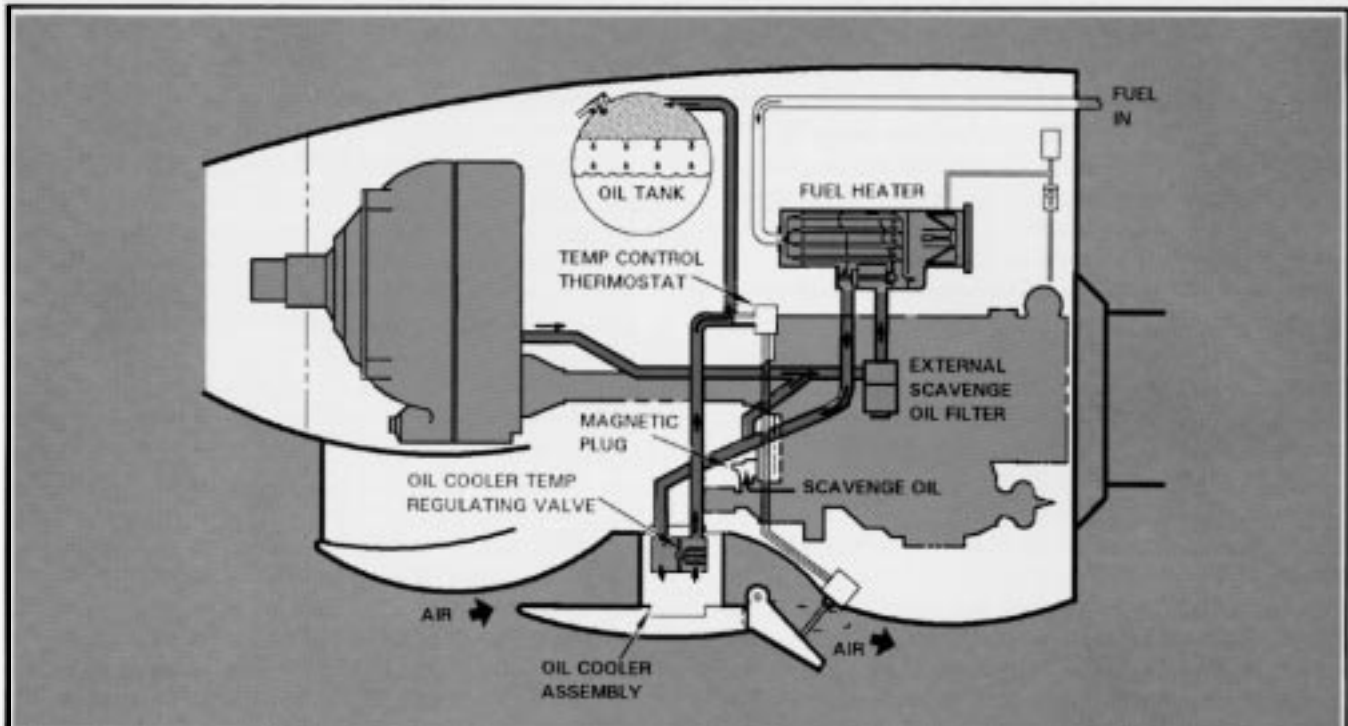

scavenge filter inlet, the external scavenge filter outlet, the oil cooler inlet, and the oil cooler outlet.

(1) External Scavenge Filter Inlet

The reading here indicates the overall pressure to which the scavenge pumps are subjected (Fig. 4). This pressure should be maintained as far below the 30 psi maximum as possible.

(2) External Scavenge Filter Outlet

The value obtained at this point is used to check the pressure differential (AP) across the external scavenge filter; in other words, the difference in pressure between the filter inlet and the filter outlet. This can help determine the condition of the filter itself. Contamination will cause an increased resistance to oil flow. In normal operation, a clean filter will have a AP of 3 to 8 psi. Any amount over 8 psi can be considered excessive.

(3) Oil Cooler Inlet

The pressure reading at this location can be compared with the external scavenge filter outlet pressure value to determine the AP across the fuel heater strainer assembly (Fig. 14). Under normal operations, a clean fuel heater in full bypass will have a AP of 7 to 12 psi. Remember, this is in the full bypass condition. In other words, the temperature of the fuel flowing through the exchanger is not cold enough to begin closing the bypass valve, and all of the oil is bypassing the exchanger.

But the fuel is not always this warm. Fuel can get very cold, especially at altitude. During a typical mission, the decreasing fuel temperature is sensed by a thermostat in the fuel heater as the aircraft climbs toward cruise altitude. The thermostat in the fuel heater then begins to close the bypass valve, which forces the returning oil up through the heat exchanger.

This action increases the AP across the exchanger even more. The problem is that it is difficult to duplicate this situation on the ground. However, the locally manufactured tool shown in Figure 14 on page 18 can help in isolating this problem. In use, the fuel heater oil bypass (slide) valve is removed and the special tool installed in its location. With the tool installed, all of the returning oil is forced through the exchanger.

When the tool is in place, normal operation of the exchanger will increase the AP to about 12 to 18 psi. Any more than 18 psi should be considered excessive. However, as long as the total overall scavenge back pressure does not exceed 30 psi with the special tool installed, the exchanger and the entire scavenge return system can be regarded as serviceable. An important thing for the troubleshooter to remember is that the fuel

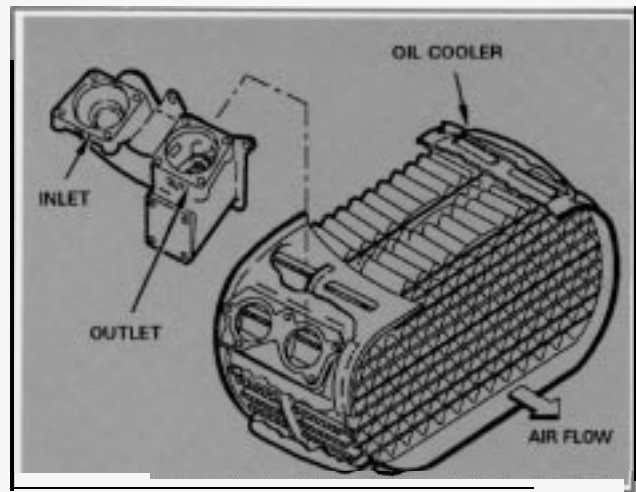

Figure 73. Even in full operation at 80°C, the AP of the oil cooler should not be more than 9 psi.

heater usually causes oil dumping at altitude only, and that scavenge back pressure without the special tool installed will often be within limits when measured on the ground.

That is not to say that the oil bypass valve could not become stuck in the closed position, causing high scavenge back pressure both at altitude and on the ground. This condition is very rare, but one must remember that the limits given above, fully open or fully closed, are extremes. The engine usually operates somewhere between these two settings. Unfortunately, this is yet another variable that the troubleshooter must contend with.

(4) Oil Cooler Outlet

This pressure reading, coupled with that of the oil cooler inlet, can help determine the condition of the interior of the oil cooler. Remember that the cooler does not come into play until the oil gets hot enough to require cooling. At 60°C oil temperature, the oil is bypassing the cooler core. The normal AP for the cooler at this temperature is 0 to 6 psi.

As the oil begins to heat up, the thermostat in the oil cooler starts to route some of the oil through the cooler core. At 75°C oil temperature and above, the bypass is fully closed and all of the oil is routed through the cooler core. This increases the AP, but even at 80°C, the AP should not be more than 9 psi. Any more than 9 psi can be regarded as excessive and suggests that the unit is becoming contaminated. Once again, however, if the overall total back pressure is below the maximum of 30 psi, the system can be considered serviceable.

It is clear from the foregoing that the way the oil cooler affects scavenge back pressure is closely related to oil temperature. This fact can prove useful during troubleshooting activities. If the scavenge back pressure is below 30 psi when the oil is cold and it then increases

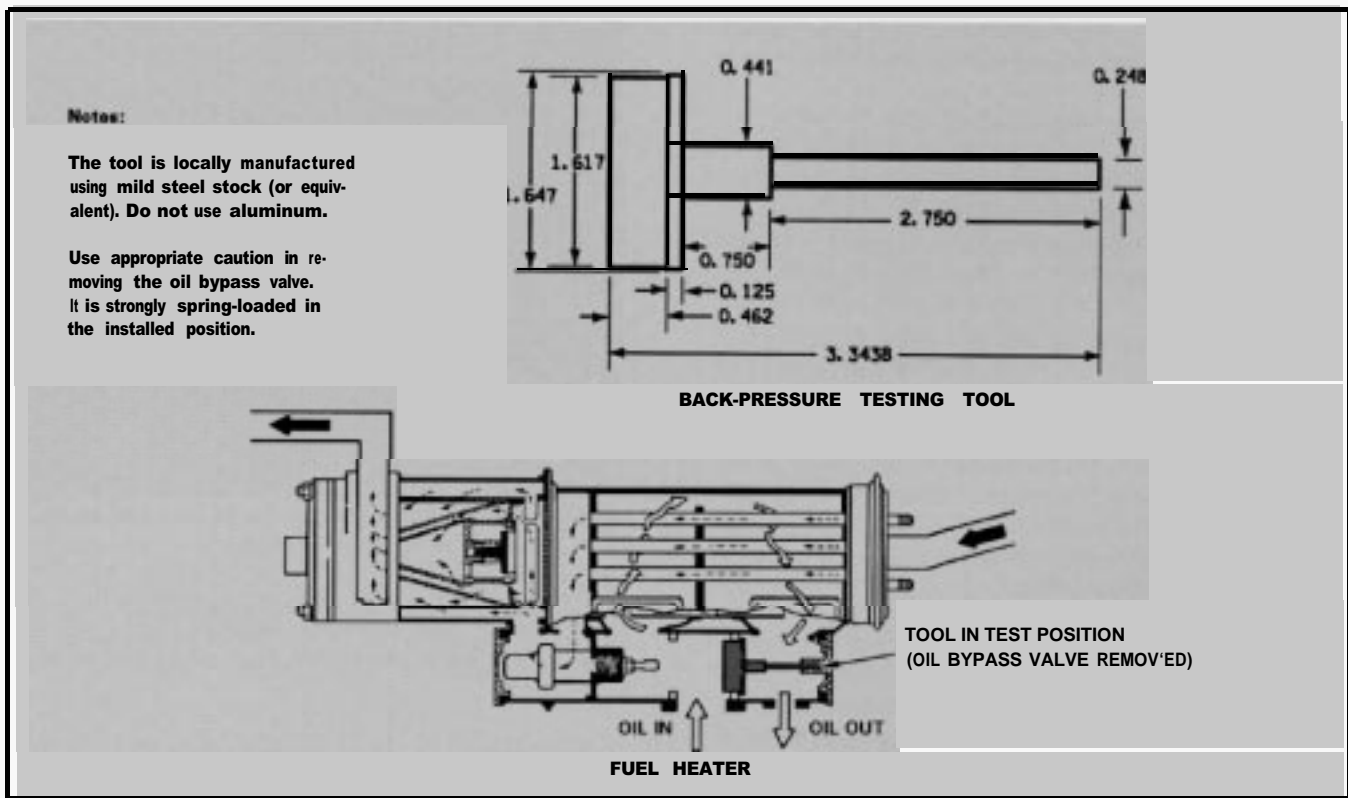

Figure 14. Installed in the fuel heater, this locally manufactured tool will allow the unit's maximum back pressure to be measured.

to above 30 psi when the oil temperature reaches between 65°C and 75°C, the likelihood is that the oil cooler is the culprit.

It is important not to lose sight of the total back pressure of the system as a whole, however. Consider an example in which the total overall back pressure is 29 psi when the oil is cold, but has risen to 33 psi at 75°C oil temperature, at which point dumping occurs. System pressure is now above normal, but the oil cooler has only raised the total back pressure by 4 psi. A 4 psi increase is within the normal operating range of a good cooler, so we must look elsewhere for the cause of the problem.

Continuing with our example, further investigation shows that the AP across the external scavenge filter is found to be 10 psi. By replacing the external scavenge filter and bringing its AP down to 4 psi, the total scavenge back pressure will be reduced to 23 psi. This is below the dumping threshold even when the extra 4 psi of the oil cooler in full operation is added. Now the overall back pressure reading will be 27 psi, and no dumping should occur. Remember to look not only at individual components, but also at the total system and what effect each component is having on it.

If it is determined that a certain component is causing the high scavenge back pressure, and that component is replaced but little change in the pressure readings results, check the condition of the oil lines

connecting the affected component. These oil lines can break down on the inside and cause restrictions. Sometimes it is simply a matter of a line being kinked.

Altitude Effects

Misconceptions about oil loss at altitude are not uncommon. The first thing that must be determined is whether altitude actually has anything to do with the problem. We have already discussed some of the many ways in which altitude can affect the oil system, but it is not uncommon for troubleshooters to get the impression that a problem is altitude-related when it is not.

Sometimes the problem involves a time factor in which oil accumulation occurs for a while before dumping begins. An example might be an engine with a restricted oil filter which raises the scavenge back pressure to, let us say, 32 psi. This creates an oil accumulation problem, but even though the pump is pumping against excessive back pressure, it is *still pumping*. The accumulation in this case will be very slow.

By the time the oil has accumulated to the dumping stage, the aircraft may have reached 20,000 feet. Then oil dumping begins, and is noted visually by the flight crew. You can see how easily a troubleshooter might be misled. Of course, flight crews can help by closely monitoring the oil quantity indicators during climbout.

The actual accumulation rate can be calculated from the difference between the flow of oil being pumped into the area versus the flow being pumped out. It all depends on how severe the leak or restriction is. With this in mind, it is easy to see why it may take several hours for the oil to accumulate to the dumping stage.

There are three components in the oil system that are directly affected by altitude (Fig. 1). The oil tank pressurization valve is a spring-loaded valve that controls the amount of pressure in the oil tank. The spring tension on the valve may become too weak and possibly cause a change in oil tank pressure, or the valve could stick open or closed and cause problems. As a practical matter, there is not too much that can go wrong with this valve because of its simplicity. Replacing it does not often correct an oil dumping problem. It is a factor which should be considered, however.

The oil tank cap should not be overlooked. Sometimes the tank cap is improperly seated or the seal may be defective. Normally there are no problems until the pressure on the outside of the tank is reduced, which of course happens at altitude. The oil may then flow from the cap and very possibly out the scupper drain. This is due to the venturi effect of the drain mast saber, which creates suction at the scupper. But there may also be no evidence of an external oil leak at all.

As noted earlier, the operation of the fuel heater strainer assembly is indirectly related to altitude in that it responds to fuel temperature, which usually becomes lower at altitude. When the fuel cools, oil is directed into the heat exchanger. If this unit is overly contaminated, high scavenge back pressure at altitude can result.

One more thing to consider. There have been cases recorded where changing the oil fixed an altitude dumping problem. As strange as it may seem, this can and does occur. Engine oil has an anti-foaming agent added. When oil is left undisturbed for a long period of time, the agent separates from the oil and goes to the bottom of the container. If the container is not shaken or the oil mixed prior to servicing, the agent may get left in the container. When this happens, the oil foams excessively at altitude and exits through the venting system. Mixing incompatible oils can also cause excessive foaming and oil loss.

Preventive Maintenance

One of the keys to successful 501/T56 engine operation is a sound preventive maintenance program. This has been proven throughout the world as one of the most important elements in the satisfactory completion of Hercules aircraft missions. It holds true for the oil system as well.

The primary thing for the maintainer to be concerned with is identifying a potential problem ahead of

time. Although a little extra effort must be exerted, there are a number of things he can do to prevent oil system problems from developing.

Check for accumulation. Engines are operated periodically throughout the maintenance program, usually on a scheduled basis: test cell, pre-ISO, back line, or compressor washes. It is during these operational checks that inspection for oil accumulation can be made. Simply drain and measure the amounts of oil from the reduction gear assembly and accessory drive housing after the run. If too much oil is drained from either location, a potential problem may exist and troubleshooting should begin. It makes little sense to wait until oil begins to dump in flight, possibly interfering with a priority mission.

Keep records. It is a good idea to keep records of static oil leakers. This way, transient problems can easily be separated from repeat offenders. Repeat offenders need to be thoroughly checked out and the malfunctioning components replaced.

Monitor lighthouse pressure. Lighthouse pressure can be taken during the operational checks mentioned above. If the pressure is getting close to the 1 l-inch Hg limit, the engine should be scheduled for removal and repair at the earliest possible time.

Keep critical components clean. During the in-shop repair cycle, many components of the common oil return system are removed. This is a good time to make the effort to clean these components so that when they are reinstalled they will not create problems with back pressure. Ensure that new, clean filters are installed. Oil coolers and fuel heaters should be cleaned before installation.

Go all the way with maintenance. When an engine has been removed for oil accumulation in the lighthouse area, there are certain extra steps that can be taken in the shop that may avoid future failures. For instance, we know that oil is used to keep bearings cool. If lighthouse accumulation has occurred, there is a good chance the bearings have been overheated. So while the engine is disassembled, replace both the turbine front and the compressor rear bearings.

While the material offered in this article is by no means all-inclusive, we hope it will prove helpful and useful to the many 501/T56 engine maintainers throughout the world.

Service News wishes to express its appreciation to the Allison Gas Turbine Division Training Department and the Lockheed (LASC) Customer Training Systems Department for the use of the illustrations accompanying this article.



Lockheed

Aeronautical Systems Company

Customer Training Systems Department

Lockheed - LASC

Marietta, GA 30063



*VR 54 Celebrates a New Beginning. . .
. . . With the World's Favorite Airlifter!*